



Modular Cooking Range Line 900XP 4-Burner Gas Range 10 kW on Convection Oven

ITEM # _____

MODEL # _____

NAME # _____

SIS # _____

AIA # _____



391009 (E9GCGH4CVM)

4-Burner (10 kW each) gas
Range on gas Convection
Oven (10,5 kW)

Short Form Specification

Item No. _____

To be installed on stainless steel feet with height adjustment up to 50 mm. High efficiency flower flame burners with continuous power regulation and optimized combustion. Flame failure device as standard on burners to protect against accidental extinguishing. Oven chamber with 2 levels of runners to accommodate 2/1 GN shelves (2 steam pans). Ribbed, enamelled steel oven base plate. Exterior panels of unit in stainless steel with Scotch Brite finish. Pan supports in heavy duty cast iron. Extra strength work top in heavy duty 2 mm stainless steel. Right-angled side edges to allow flush-fitting junction between units.

Main Features

- Unit to be mounted on stainless steel feet with height adjustment up to 50 mm. Unit can be easily mounted on cantilever systems.
- The four 10 kW high efficiency burners are available in 100 mm diameter with continuous power regulation from 2.2 kW to 10 kW.
- Gas appliance supplied for use with natural or LPG gas, conversion jets supplied as standard.
- Large sized pan support in cast iron (stainless steel as option) with long center fins to allow the use of the largest down to the smallest pans.
- Burners with optimized combustion.
- Flame failure device on each burner protects against gas leakage when accidental extinguishing of the flame occurs.
- Protected pilot light.
- Base compartment consists of a convection oven, with ON/OFF switch between static and convection mode, positioned beneath the base plate. Oven chamber to have 2 levels of runners to accommodate 2/1 GN shelves (2 steam pans) and ribbed enamelled steel base plate.
- Convection oven allows for simultaneous cooking on 2 levels thus reducing cooking times compared to standard static ovens (depending on food type).
- Oven thermostat adjustable from 120 °C to 280 °C.
- 40 mm thick oven door for heat insulation.
- The special design of the control knob system guarantees against water infiltration.
- IPX5 water protection.

Construction

- Unit is 930 mm deep to give a larger working surface area.
- All exterior panels in Stainless Steel with Scotch Brite finishing.
- AISI 304 stainless steel worktop, 2mm thick.
- Model has right-angled side edges to allow flush fitting joints between units, eliminating gaps and possible dirt traps.
- Delivered with upstand chimney, mandatory to be installed.

Included Accessories

- 2 of GN2/1 chrome plated grid for convection oven PNC 206243
- 1 of Chimney upstand, 800mm PNC 206304

APPROVAL: _____



Experience the Excellence
www.electroluxprofessional.com



900XP 4-Burner Gas Range 10 kW on Convection Oven
Modular Cooking Range Line

Optional Accessories

- GN2/1 chrome grid for static oven PNC 164250
- Junction sealing kit PNC 206086
- Draught diverter, 150 mm diameter PNC 206132
- Matching ring for flue condenser, 150 mm diameter PNC 206133
- Kit 4 wheels - 2 swivelling with brake - it is mandatory to install Base support and wheels PNC 206135
- Flanged feet kit PNC 206136
- Frontal kicking strip for concrete installation, 800mm PNC 206148
- Frontal kicking strip for concrete installation, 1000mm PNC 206150
- Frontal kicking strip for concrete installation, 1200mm PNC 206151
- Frontal kicking strip for concrete installation, 1600mm PNC 206152
- Pair of side kicking strips for concrete installation PNC 206157
- Single burner ribbed plate for direct cooking - fits frontal burners only PNC 206172
- Frontal kicking strip, 800mm (not for refr-freezer base) PNC 206176
- Frontal kicking strip, 1000mm (not for refr-freezer base) PNC 206177
- Frontal kicking strip, 1200mm (not for refr-freezer base) PNC 206178
- Frontal kicking strip, 1600mm (not for refr-freezer base) PNC 206179
- Pair of side kicking strips (not for refr-freezer base) PNC 206180
- 2 panels for service duct for single installation PNC 206181
- 2 panels for service duct for back to back installation PNC 206202
- Kit 4 feet for concrete installation (not for 900 line free standing grill) PNC 206210
- GN2/1 chrome plated grid for convection oven PNC 206243
- Flue condenser for 1 module, 150 mm diameter PNC 206246
- Water column with swivel arm (water column extension not included) PNC 206289
- Water column extension for 900 line PNC 206290
- Stainless steel double grid for 2 burners PNC 206298
- Chimney upstand, 800mm PNC 206304
- Back handrail 800mm, Marine PNC 206308
- Back handrail 1200mm, Marine PNC 206309
- Wok pan support for open burners (700/900) PNC 206363
- Base support for feet or wheels - 800mm (700/900) PNC 206367
- Base support for feet or wheels - 1200mm (700/900) PNC 206368
- Base support for feet or wheels - 1600mm (700/900) PNC 206369
- Base support for feet or wheels - 2000mm (700/900) PNC 206370
- Rear paneling - 800mm (700/900) PNC 206374
- Rear paneling - 1000mm (700/900) PNC 206375
- Rear paneling - 1200mm (700/900) PNC 206376
- Chimney grid net, 400mm (700XP/900) PNC 206400
- Side handrail-right/left hand (900XP) PNC 216044
- Frontal handrail, 800mm PNC 216047
- Frontal handrail, 1200mm PNC 216049
- Frontal handrail, 1600mm PNC 216050
- 2 side covering panels for free standing appliances PNC 216134
- Large handrail - portioning shelf, 400mm PNC 216185
- Large handrail - portioning shelf, 800mm PNC 216186
- Pressure regulator for gas units PNC 927225

Front

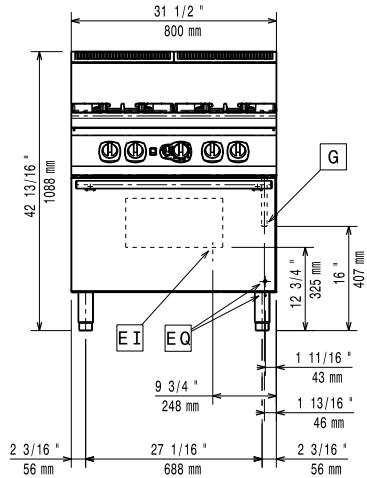

Side

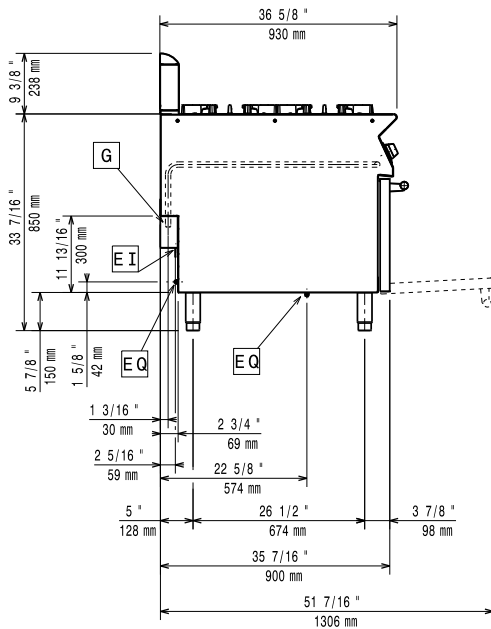

EI = Electrical inlet (power)
 G = Gas connection

Top

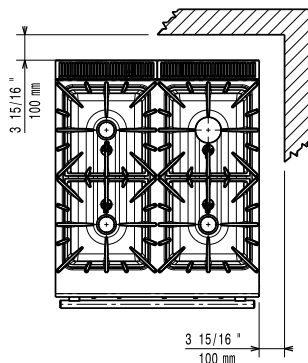

Electric

Supply voltage:

391009 (E9GCGH4CVM) 220-230 V/1 ph/50/60 Hz

Electrical power max.:

0.2 kW

Gas

Gas Power:

50.5 kW

Standard gas delivery:

Natural Gas G20 (20mbar)

Gas Type Option:

LPG; Natural Gas

Gas Inlet:

1/2"

Key Information:

Front Burners Power:

10 - 10 kW

Back Burners Power:

10 - 10 kW

Back Burners Dimension - mm

Ø 100 Ø 100

Front Burners Dimension - mm

Ø 100 Ø 100

Oven Heat Input:

10.5 kW

Oven working Temperature:

120 °C MIN; 280 °C MAX

Oven Cavity Dimensions (width):

560 mm

Oven Cavity Dimensions (height):

270 mm

Oven Cavity Dimensions (depth):

680 mm

External dimensions, Width:

800 mm

External dimensions, Height:

850 mm

External dimensions, Depth:

930 mm

Net weight:

159 kg

Shipping weight:

174 kg

Shipping height:

1090 mm

Shipping width:

1020 mm

Shipping depth:

860 mm

Shipping volume:

0.96 m³

If appliance is set up or next to or against temperature sensitive furniture or similar, a safety gap of approximately 150 mm should be maintained or some form of heat insulation fitted.

Certification group:

N9CG