

Modular Cooking Range Line 900XP 2-Hot Plates Electric Boiling Top

ITEM # _____

MODEL # _____

NAME # _____

SIS # _____

AIA # _____



- | | |
|----------------------------|--|
| 391039 (E9ECED2Q00) | 2-Hot Square Plates (4 kW each) electric Boiling Top |
| 391165 (E9ECED2Q0N) | 2-Hot Plate (4 kW each) electric Boiling Top |

Short Form Specification

Item No. _____

To be installed on open base installations, bridging supports or cantilever systems. Two 4 kW square cast-iron hot plates hermetically sealed to the one-piece top. Exterior panels of unit in stainless steel with Scotch Brite finish. Extra strength work top in heavy duty 2 mm stainless steel. Right-angled side edges to allow flush-fitting junction between units.

Main Features

- Unit to be mounted on open base cupboards, bridging supports or cantilever systems.
- The two 4kW cast-iron plates are hermetically sealed to the one-piece top. Hot plates with a power of 4kW for each plate.
- The special design of the control knob system guarantees against water infiltration.
- IPX5 water protection.
- Top configuration allows installation on ambient base only (not possible to install on refrigerated nor freezer base).

Construction

- Unit is 930 mm deep to give a larger working surface area.
- All exterior panels in Stainless Steel with Scotch Brite finishing.
- AISI 304 stainless steel worktop, 2mm thick.
- Model has right-angled side edges to allow flush fitting joints between units, eliminating gaps and possible dirt traps.

APPROVAL: _____

Optional Accessories

- Pair of cast iron plate bars for electric cooking top PNC 206056
- Junction sealing kit PNC 206086
- Support for bridge type installation, 800mm PNC 206137
- Support for bridge type installation, 1000mm PNC 206138
- Support for bridge type installation, 1200mm PNC 206139
- Support for bridge type installation, 1400mm PNC 206140
- Support for bridge type installation, 1600mm PNC 206141
- Support for bridge type installation, 400mm PNC 206154
- Water column with swivel arm (water column extension not included) PNC 206289
- Water column extension for 900 line PNC 206290
- Chimney upstand, 400mm PNC 206303
- Back handrail 800mm, Marine PNC 206308
- Back handrail 1200mm, Marine PNC 206309
- Chimney grid net, 400mm (700XP/900) PNC 206400
- Side handrail-right/left hand (900XP) PNC 216044
- Frontal handrail, 400mm PNC 216046
- Frontal handrail, 800mm PNC 216047
- Frontal handrail, 1200mm PNC 216049
- Frontal handrail, 1600mm PNC 216050
- Large handrail - portioning shelf, 400mm PNC 216185
- Large handrail - portioning shelf, 800mm PNC 216186
- 2 side covering panels for top appliances PNC 216278

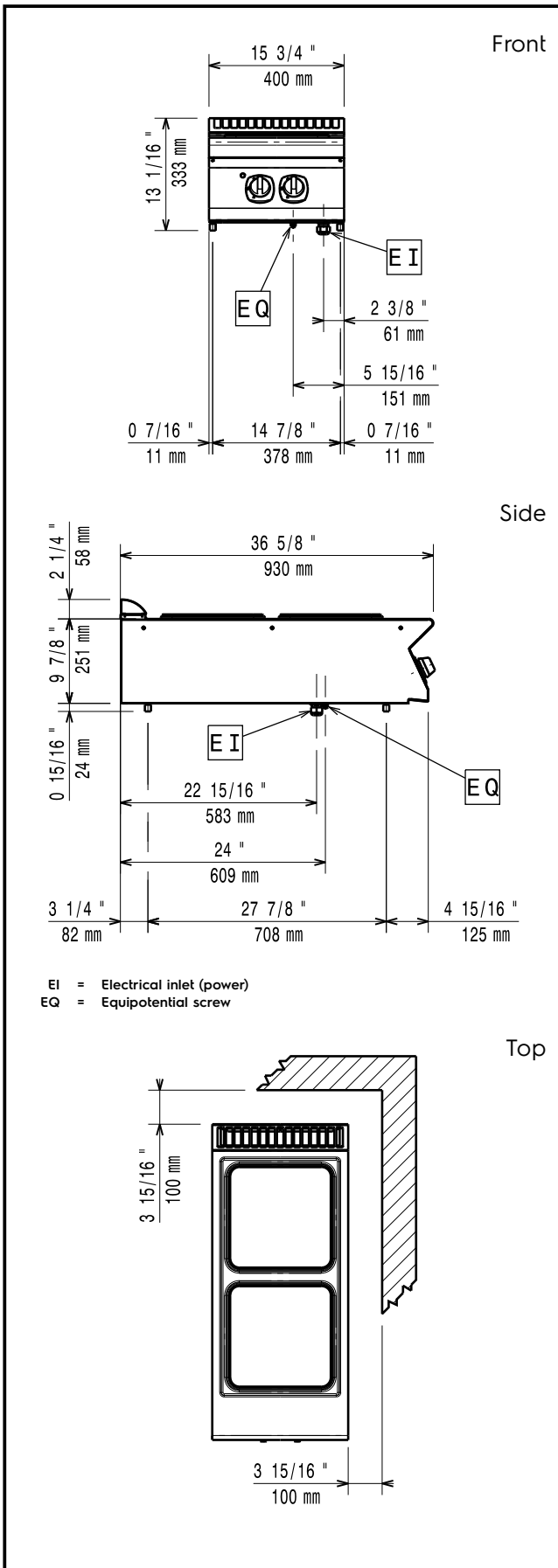

Electric

Supply voltage:

391039 (E9ECED2Q00)	380-400 V/3N ph/50/60 Hz
391165 (E9ECED2Q0N)	230 V/3 ph/50/60 Hz

Total Watts:

8 kW

Predisposed for:

391039 (E9ECED2Q00)	380-400V 3N~ 50/60Hz 7,5-8kW
---------------------	---------------------------------

Key Information:

Front Plates Power:	4 - 0 kW
Back Plates Power:	4 - kW
Front Plates dimensions:	300x300
Back Plates dimensions:	300x300
External dimensions, Width:	400 mm
External dimensions, Height:	250 mm
External dimensions, Depth:	930 mm
Net weight:	35 kg

Shipping weight:

391039 (E9ECED2Q00)	43 kg
391165 (E9ECED2Q0N)	45 kg

Shipping height:

391039 (E9ECED2Q00)	520 mm
391165 (E9ECED2Q0N)	540 mm

Shipping width:

460 mm

Shipping depth:

1020 mm

Shipping volume:

391039 (E9ECED2Q00)	0.24 m ³
391165 (E9ECED2Q0N)	0.25 m ³

Certification group:

391039 (E9ECED2Q00)	EH92T
391165 (E9ECED2Q0N)	N9CEI

If appliance is set up or next to or against temperature sensitive furniture or similar, a safety gap of approximately 150 mm should be maintained or some form of heat insulation fitted.