

Modular Cooking Range Line 900XP 4 Electric Hot Plate Range on Electric Oven

ITEM # _____

MODEL # _____

NAME # _____

SIS # _____

AIA # _____

391041 (E9ECEH4QE0)

4-Hot Square Plates (4 kW each) electric Range on electric Oven (6 kW)

391167 (E9ECEH4QEN)

4-Hot Plate (4 kW each) electric Range on electric Oven (6 kW)

Short Form Specification

Item No.

Unit to be Electrolux 900XP four 4kW electric hot plate range on electric oven. Electric characteristics to be __400V or __230V. Unit to be installed on stainless steel feet with height adjustment up to 50 mm. Unit to have cast-iron hot plates hermetically sealed to the one-piece top. Oven chamber with 3 levels of runners to accommodate 2/1 GN shelves (2 steam pans). Unit to have ribbed, cast-iron oven base plate. Exterior panels of unit in Stainless steel with Scotch Brite finish. Extra strength work top in heavy duty 2 mm Stainless steel. Unit has right-angled side edges to allow flush-fitting junction between units.

Main Features

- Unit to be mounted on stainless steel feet with height adjustment up to 50 mm. Unit can be easily mounted on cantilever systems.
- The four 4kW electric cast-iron hot plates are hermetically sealed to the one piece top and are featured with safety thermostat.
- Base compartment consists of an electric standard oven with 40 mm thick oven door for heat insulation, positioned beneath the base plate.
- Oven chamber with 3 levels of runners to accommodate 2/1 GN shelves (2 steam pans).
- Ribbed cast iron oven base plate.
- Oven to feature separate thermostats for top and bottom elements. Thermostat temperature adjustable from 110°C to 285°C.
- The special design of the control knob system guarantees against water infiltration.
- IPX5 water protection.
- Top configuration allows installation on ambient base only (not possible to install on refrigerated nor freezer base).

Construction

- Unit is 930 mm deep to give a larger working surface area.
- All exterior panels in Stainless Steel with Scotch Brite finishing.
- AISI 304 stainless steel worktop, 2mm thick.
- Model has right-angled side edges to allow flush fitting joints between units, eliminating gaps and possible dirt traps.

Included Accessories

- 1 of GN2/1 chrome grid for static oven PNC 164250

Optional Accessories

- GN2/1 chrome grid for static oven PNC 164250
- Pair of cast iron plate bars for electric cooking top PNC 206056
- Junction sealing kit PNC 206086
- Kit 4 wheels - 2 swivelling with brake - it is mandatory to install Base support and wheels PNC 206135
- Flanged feet kit PNC 206136
- Frontal kicking strip for concrete installation, 800mm PNC 206148
- Frontal kicking strip for concrete installation, 1000mm PNC 206150

APPROVAL: _____

- Frontal kicking strip for concrete installation, 1200mm PNC 206151
 - Frontal kicking strip for concrete installation, 1600mm PNC 206152
 - Pair of side kicking strips for concrete installation PNC 206157
 - Frontal kicking strip, 800mm (not for refr-freezer base) PNC 206176
 - Frontal kicking strip, 1000mm (not for refr-freezer base) PNC 206177
 - Frontal kicking strip, 1200mm (not for refr-freezer base) PNC 206178
 - Frontal kicking strip, 1600mm (not for refr-freezer base) PNC 206179
 - Pair of side kicking strips (not for refr-freezer base) PNC 206180
 - 2 panels for service duct for single installation PNC 206181
 - 2 panels for service duct for back to back installation PNC 206202
 - Kit 4 feet for concrete installation (not for 900 line free standing grill) PNC 206210
 - Water column with swivel arm (water column extension not included) PNC 206289
 - Water column extension for 900 line PNC 206290
 - Chimney upstand, 800mm PNC 206304
 - Back handrail 800mm, Marine PNC 206308
 - Back handrail 1200mm, Marine PNC 206309
 - Base support for feet or wheels - 800mm (700/900) PNC 206367
 - Base support for feet or wheels - 1200mm (700/900) PNC 206368
 - Base support for feet or wheels - 1600mm (700/900) PNC 206369
 - Base support for feet or wheels - 2000mm (700/900) PNC 206370
 - Rear paneling - 800mm (700/900) PNC 206374
 - Rear paneling - 1000mm (700/900) PNC 206375
 - Rear paneling - 1200mm (700/900) PNC 206376
 - Chimney grid net, 400mm (700XP/900) PNC 206400
 - Side handrail-right/left hand (900XP) PNC 216044
 - Frontal handrail, 800mm PNC 216047
 - Frontal handrail, 1200mm PNC 216049
 - Frontal handrail, 1600mm PNC 216050
 - 2 side covering panels for free standing appliances PNC 216134
- Large handrail - portioning shelf, 800mm PNC 216186

Front

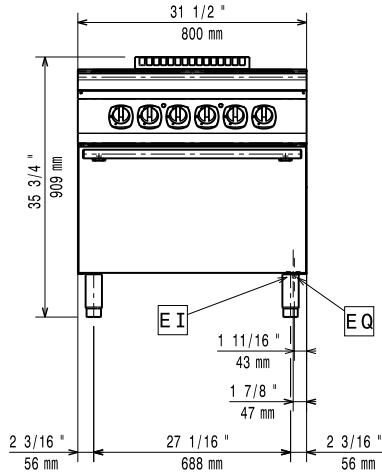

Side

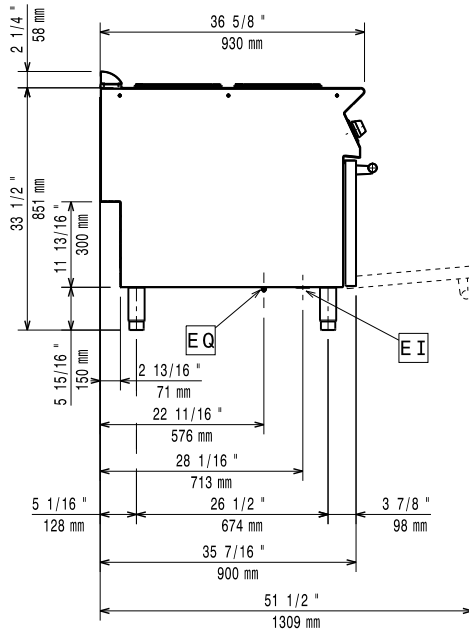

EI = Electrical inlet (power)
 EQ = Equipotential screw

Top

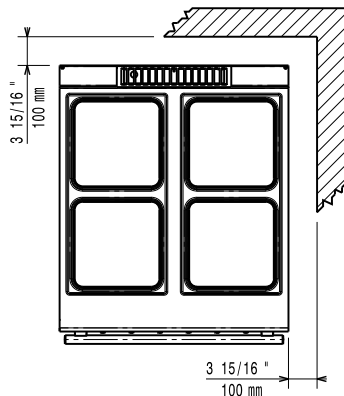

Electric

Supply voltage:

391041 (E9ECEH4QE0) 380-400 V/3N ph/50/60 Hz
 391167 (E9ECEH4QEN) 230 V/3 ph/50/60 Hz

Electrical power max.:

22 kW

Total Watts:

22 kW

Predisposed for:

391041 (E9ECEH4QE0) 380-400V 3N- 50/60Hz
 20-22kW

Key Information:

Front Plates Power:	4 - 4 kW
Back Plates Power:	4 - 4 kW
Front Plates dimensions:	300x300 300x300
Back Plates dimensions:	300x300 300x300
Oven Heat Input:	6 kW
Oven working Temperature:	110 °C MIN; 285 °C MAX
Oven Cavity Dimensions (width):	575 mm
Oven Cavity Dimensions (height):	300 mm
Oven Cavity Dimensions (depth):	700 mm
External dimensions, Width:	800 mm
External dimensions, Height:	850 mm
External dimensions, Depth:	930 mm
Net weight:	
391041 (E9ECEH4QE0)	120 kg
391167 (E9ECEH4QEN)	145 kg
Shipping weight:	
391041 (E9ECEH4QE0)	141 kg
391167 (E9ECEH4QEN)	170 kg
Shipping height:	
391041 (E9ECEH4QE0)	1080 mm
391167 (E9ECEH4QEN)	1120 mm
Shipping width:	1020 mm
Shipping depth:	860 mm
Shipping volume:	
391041 (E9ECEH4QE0)	0.95 m ³
391167 (E9ECEH4QEN)	0.98 m ³

If appliance is set up or next to or against temperature sensitive furniture or similar, a safety gap of approximately 150 mm should be maintained or some form of heat insulation fitted.

Certification group:

391041 (E9ECEH4QE0) EH94O
 391167 (E9ECEH4QEN) N9CEI