

## Modular Cooking Range Line 900XP Electric Bain Marie Top Full module

ITEM # \_\_\_\_\_

MODEL # \_\_\_\_\_

NAME # \_\_\_\_\_

SIS # \_\_\_\_\_

AIA # \_\_\_\_\_



391125 (E9BMEHB000)

 Full module electric Bain-  
marie Top

### Short Form Specification

#### Item No.

Incoloy armoured heating elements positioned under the base of the well. Used to keep cooked food at serving temperature using hot water inside the well. Water temperature to be controlled by thermostat with maximum temperature of 90 °C. Exterior panels of unit in stainless steel with Scotch Brite finish. Extra strength work top in heavy duty 2 mm stainless steel. Right-angled side edges to allow flush-fitting junction between units.

### Main Features

- Bain Marie used for keeping cooked food at serving temperatures using hot water.
- Incoloy armoured heating elements positioned under the base of the well.
- Knob switch.
- Water basin is seamlessly welded into the top of the appliance.
- Filling water level is plate-marked on the side of the well.
- Unit to feature manual refill of well.
- Water temperature controlled by thermostat with maximum temperature value of 90 °C.
- Basin drained by drain valve with overflow.
- Special insulation beneath cooking surface keeps heat on the plate without dispersion to the base.
- Unit to have perforated false bottom and runner support for GN containers.
- All major compartments located in front of unit for ease of maintenance.
- The special design of the control knob system guarantees against water infiltration.
- IPX5 water protection.
- Top configuration allows installation on ambient base only (not possible to install on refrigerated nor freezer base).

### Construction

- Unit is 930 mm deep to give a larger working surface area.
- All exterior panels in Stainless Steel with Scotch Brite finishing.
- AISI 304 stainless steel worktop, 2mm thick.
- Model has right-angled side edges to allow flush fitting joints between units, eliminating gaps and possible dirt traps.

### Optional Accessories

- Junction sealing kit PNC 206086
- Support for bridge type installation, 800mm PNC 206137
- Support for bridge type installation, 1000mm PNC 206138
- Support for bridge type installation, 1200mm PNC 206139
- Support for bridge type installation, 1400mm PNC 206140
- Support for bridge type installation, 1600mm PNC 206141
- Chimney upstand, 800mm PNC 206304

APPROVAL: \_\_\_\_\_

- Side handrail-right/left hand (900XP)  PNC 216044
- Frontal handrail, 800mm  PNC 216047
- Frontal handrail, 1200mm  PNC 216049
- Frontal handrail, 1600mm  PNC 216050
- Large handrail - portioning shelf, 800mm  PNC 216186
- 2 side covering panels for top appliances  PNC 216278
- Drilled false bottom full module for bain-marie  PNC 921623
- Water filling tap for bain-marie top  PNC 921627

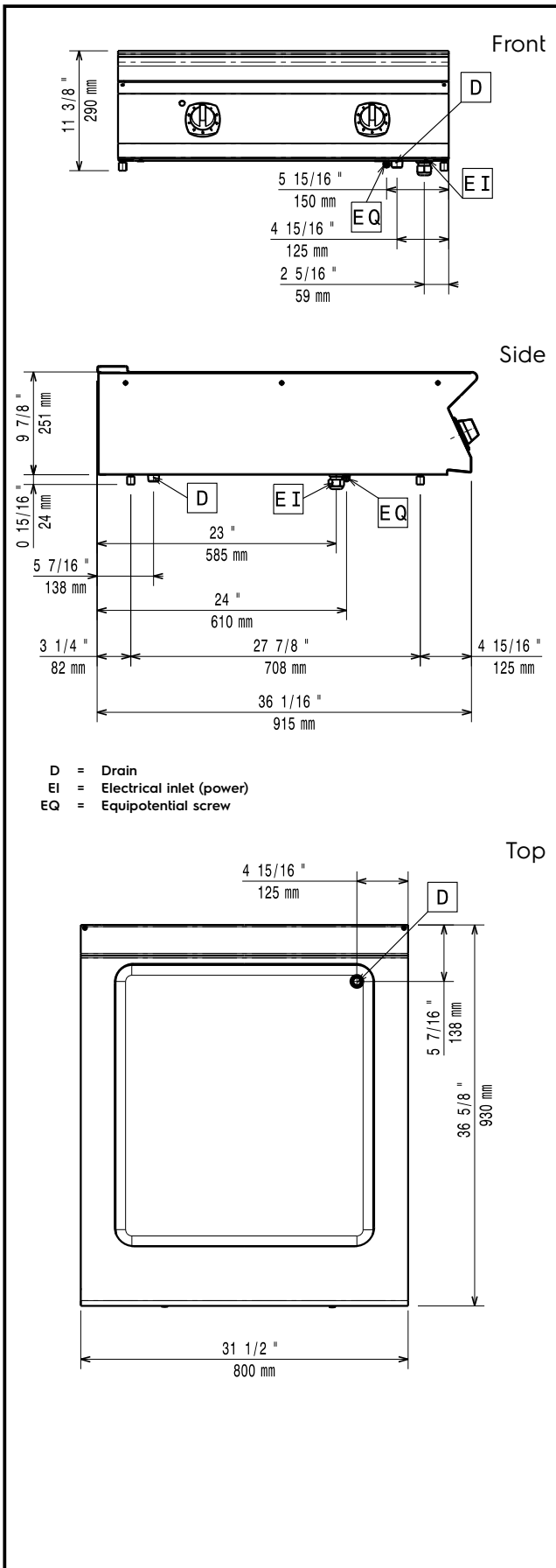

### Electric

<b>Supply voltage:</b>	<b>391125 (E9BMEHB000)</b>	380-400 V/2N ph/50/60 Hz
<b>Total Watts:</b>		4.4 kW
<b>Predisposed for:</b>		380-400V 2N- 50/60Hz
		4-4,4kW

### Water:

<b>Water Drain:</b>	50 mm
---------------------	-------

### Key Information:

<b>Usable well dimensions (width):</b>	630 mm
<b>Usable well dimensions (height):</b>	160 mm
<b>Usable well dimensions (depth):</b>	685 mm
<b>Thermostat Range:</b>	30 °C MIN; 90 °C MAX
<b>External dimensions, Width:</b>	800 mm
<b>External dimensions, Height:</b>	250 mm
<b>External dimensions, Depth:</b>	930 mm
<b>Net weight:</b>	45 kg
<b>Shipping weight:</b>	45 kg
<b>Shipping height:</b>	530 mm
<b>Shipping width:</b>	1010 mm
<b>Shipping depth:</b>	860 mm
<b>Shipping volume:</b>	0.46 m <sup>3</sup>
<b>Certification group:</b>	N9BE

If appliance is set up or next to or against temperature sensitive furniture or similar, a safety gap of approximately 150 mm should be maintained or some form of heat insulation fitted.