

Libero Line Series Mini Combi Oven

ITEM # _____

MODEL # _____

NAME # _____

SIS # _____

AIA # _____

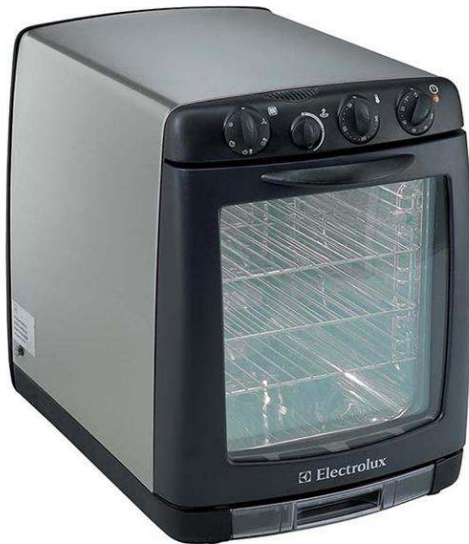
240913 (CCO30)

Electric combi oven 3 GN 1/2, four cook functions: low temperature steam, maximum steam cooking, convection cooking and combined steam/convection cooking.

Short Form Specification

Item No.

Unit shall be Electrolux Mini Combi 260913 and shall feature: steam, convection and mixed cooking modes. Accommodates half sized steam pans in 5 rack positions. Plug & Cook, mobile tabletop appliance. 230 V single phase electric. Cord and plug included. No water connection required. Self-contained water tank is an optional accessory.

Main Features

- Self contained with built-in fresh water/condense container and requires no water or drain connections.
- Delicate foods, such as fish, cook in the gentle heat of low temperature steam, retaining the full flavor and texture.
- Reheat chilled food in low temperature steam, without it drying out and losing its "freshness".
- Cooks vegetables in maximum steam, without loss of vitamins or flavor.
- Fan assisted air circulation enables convection cooking at a lower temperature with even results over the three oven shelves.
- Combining steam and convection heating produces a moist heat that reduces shrinkage whilst still browning meat.
- Side hangers, removable without use of tools, suitable for 3x1/2GN.
- Supplied with the following 1/2GN accessories: N. 1 aluminum baking plate, N. 1 stainless steel perforated container, N. 2 stainless steel plain containers and N. 1 stainless steel wire grid.

Construction

- Stainless steel oven cavity with rounded corners.

Included Accessories

- 1 of Plain container, stainless steel, 1/2 GN, h 65mm PNC 329040
- 1 of Perforated container, stainless steel, 1/2 GN, h 40mm PNC 921180
- 1 of Plain container, stainless steel, 1/2 GN, h 40mm PNC 921181
- 1 of Wire grid, stainless steel, GN 1/2, h 5mm PNC 921182
- 1 of Baking plate, non-stick aluminium, GN 1/2, h 5mm PNC 921183

Optional Accessories

- Plain container, stainless steel, 1/2 GN, h 65mm PNC 329040
- Perforated container, stainless steel, 1/2 GN, h 40mm PNC 921180
- Plain container, stainless steel, 1/2 GN, h 40mm PNC 921181
- Wire grid, stainless steel, GN 1/2, h 5mm PNC 921182
- Baking plate, non-stick aluminium, GN 1/2, h 5mm PNC 921183

APPROVAL: _____

Front

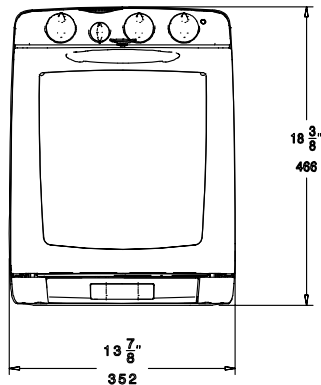

Side

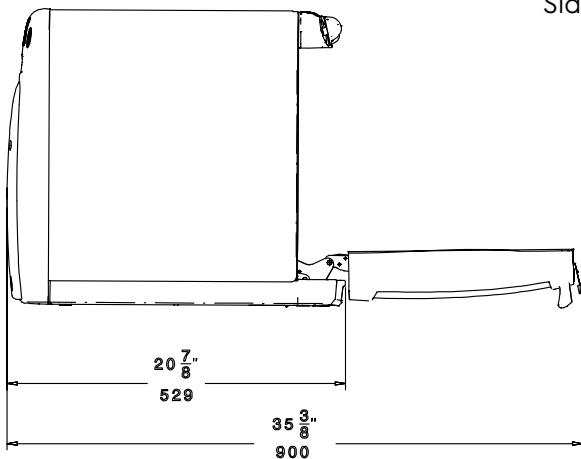
 EI = Electrical inlet (power)
 EO = Electrical Outlet

Top

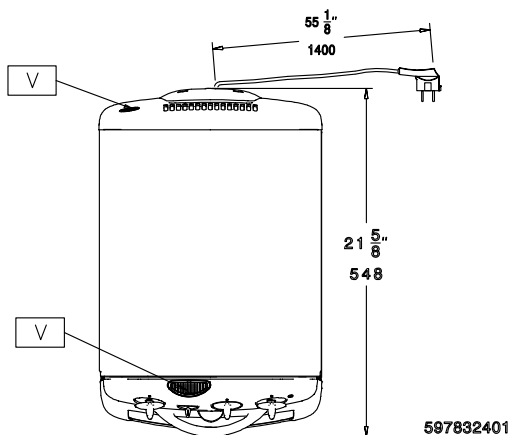

597832401

Electric

Supply voltage:	
240913 (CCO30)	220-240 V/1 ph/50 Hz
Total Watts:	2.15 kW
Minimum Circuit Ampacity (MCA):	9.5A

Key Information:

External dimensions, Width:	352 mm
External dimensions, Height:	466 mm
External dimensions, Depth:	548 mm
Plug Type	1phase: Schuko; 3phase: CEE
Net weight:	22 kg

Roast Pork (1 kg):	Combi mode - 60 to 65 min.
Fillet of beef in pastry (1.2 kg):	Convection - 30 to 40 min.
Salmon steaks baked in foil (1.2 kg):	Max. Steam - 15 to 20 min.
Cauliflower and potato gratin (2.5 kg):	Combi - 25 to 30 min.
Fish in cream sauce (1.5 kg):	Low steam - 25 to 35 min.
Fruit muffins (24 pieces):	Convection - 15 min.

Cooking functions
Max steam

The steam temperature is above 98 °C. This rapid method of cooking featuring all the necessary precautions is particularly suited to the majority of foodstuffs cooked in water. The foodstuffs conserve their vitamins as well as their shape and color. This method is used above all for vegetables and potatoes. The food can be cooked just as well in the plain containers as in the perforated containers.

Low steam

The steam temperature is about 85 °C. Low steam is a combination between high humidity and precise temperature control. This method protects the dishes while conserving their mineral salts and vitamins, as well as their taste, form and color. Low steam means slow even cooking. Foodstuff weight loss is kept to a minimum. This method of cooking is ideal for fish and pâtés, warming up meat dishes, and also for heating up "vacuum-packed" products.

Combi cooking

The combination of hot air and steam is an intelligent method of cooking. The higher humidity ensures delicate heating and a juicier roasting surface. The intensity of the hot air and the conducting of the heat through the steam seals the outside surface of the dishes more rapidly, trapping the moisture inside the roast and giving less weight loss.

Convection heat

This method is suitable for roasting. You can also use it to cook fillets of fish and meat, cutlets, pâtés, potato dishes, gratins, cakes and biscuits.

Cooling function

This function is meant to be used when you want to switch from one cooking process (convection heat or combi) to another one at a much lower temperature (low and max steam). When you select this function then only the fan will be on and not the heating elements. This will enable the oven cavity temperature to cool down rapidly to a suitable temperature for heat sensitive foods (vegetable or fish). Make sure the ventilation control is set to the fully open position. If you want to speed up this cooling process even more, leave the door open while this function is selected.