

Libero Line Series Libero Point, 2 unit freestanding counter

ITEM # _____

MODEL # _____

NAME # _____

SIS # _____

AIA # _____

351060 (NELP2)

 Libero Point mobile counter.
 Suitable for 2 Libero Line
 appliances

Short Form Specification

Item No. _____

Can accommodate up to two electric table top appliances. Heavy duty stainless steel construction. Integrated radial fan (variable speed) ventilation system that reduces cooking odours from the cooking surfaces of the table top appliances. Air is filtered through the top of the appliance and released at the base. The self-contained air-filtration system is equipped with 3 filters, a dishwasher safe mechanical filter with a fine-meshed metal filter and a carbon activated filter. Large glass top suited for placing dishes to serve customers. Electrical plugs protected by covering plates. Side supports each holding n.2 GN 1/9 containers. Mounted on 4 swivelling wheels (two with brake). Rounded edges and smooth surfaces for easier cleaning. Cord and plug included. Optional accessories: drawers, tilting side shelves and customized front panels can be ordered on request.

Main Features

- Push open optional neutral drawers for additional storage space.
- Can accommodate up to two Libero Line tabletop appliances.
- Integrated variable speed fan ventilation system with multi-step filter solution to reduce cooking odors and steam from the cooking surfaces of the tabletop appliances.
- Technological 3-stage filtering system composed of: a mechanical labyrinth filter for bigger particles of grease and steam, a mesh (metallic net) filter and carbon activated filters to absorb residual humidity and odors.
- Mounted on 4 swiveling wheels.
- Compact, lightweight and easy to move.
- Rounded edges and smooth surfaces to facilitate cleaning operations.
- IP24 protected.

Construction

- Glass side splash guards and stainless steel front serving shelf.
- Side supports to hold GN 1/9 container.
- Heavy duty Stainless steel construction.

Included Accessories

- 3 of Carbon filter PNC
650069
- 1 of Support for containers right side PNC 650070
(LP2 - LP3)
- 1 of Support for containers left side PNC 650071
(LP2 - LP3)
- 2 of Labyrinth filter with stainless steel grid PNC 650072

Optional Accessories

- Tilting side shelf for Libero Point PNC
650005
- Top neutral drawer for Libero point PNC
650030
- Bottom neutral drawer for Libero point PNC
650033
- Carbon filter PNC
650069
- Support for containers right side (LP2 - LP3) PNC 650070
- Support for containers left side (LP2 - LP3) PNC 650071
- Labyrinth filter with stainless steel grid PNC 650072

APPROVAL: _____

Front

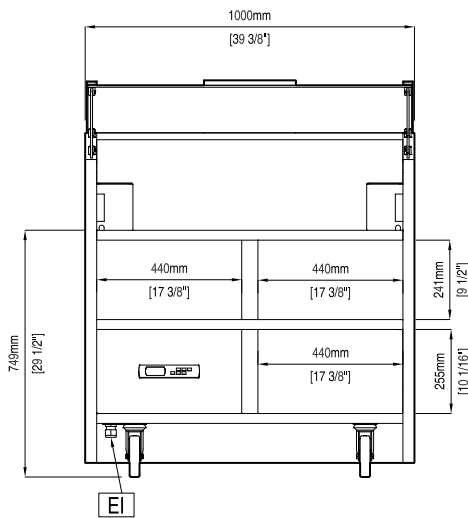

Side

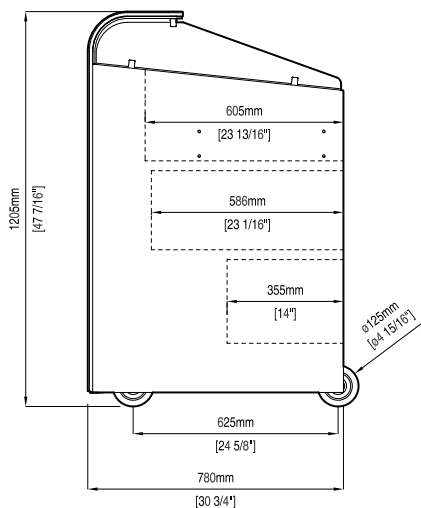

EI = Electrical inlet (power)
 EO = Electrical Outlet

Top

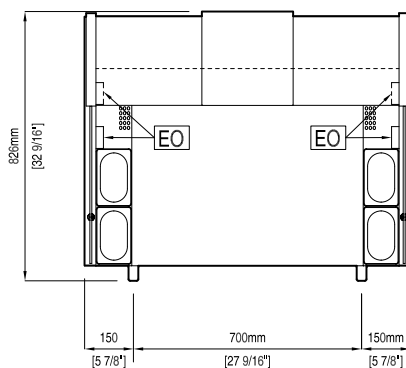

Electric

Supply voltage:	
351060 (NELP2)	400 V/3N ph/50 Hz
Electrical power max.:	0.3 kW
Plug type:	IEC/EN 60309-1/2
Minimum Circuit Ampacity (MCA):	32A

Key Information:

Aspiration capacity:	
Speed level 8:	370 m ³ /h
Speed level 10:	550 m ³ /h
External dimensions, Width:	1000 mm
External dimensions, Height:	1204 mm
External dimensions, Depth:	780 mm
Net weight:	113 kg

Induction cooktop, Infrared cooktop, Induction wok and Griddle.

Frontal power sockets available for Plug-in Units: • n° 4 Schuko plugs (1ph)