

Libero Line Series Libero Point, 2 HP unit freestanding counter

ITEM # _____

MODEL # _____

NAME # _____

SIS # _____

AIA # _____

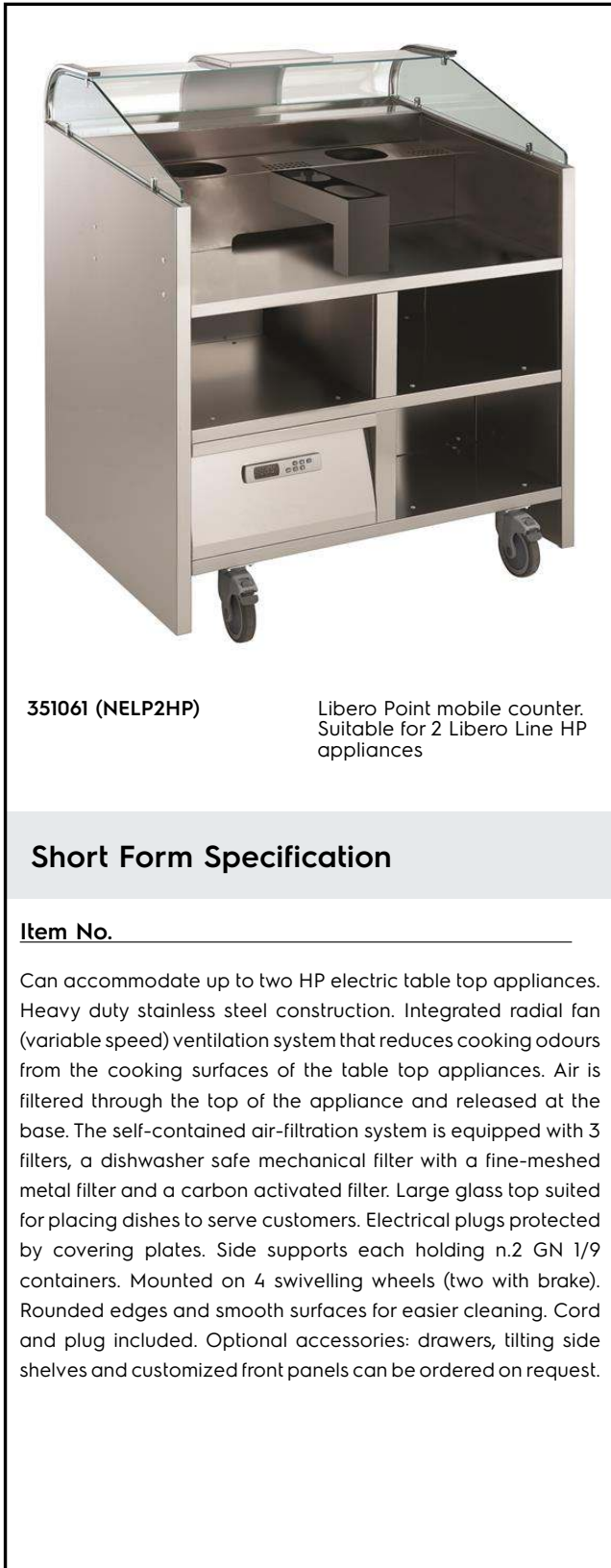
351061 (NELP2HP)

 Libero Point mobile counter.
 Suitable for 2 Libero Line HP
 appliances

Short Form Specification

Item No. _____

Can accommodate up to two HP electric table top appliances. Heavy duty stainless steel construction. Integrated radial fan (variable speed) ventilation system that reduces cooking odours from the cooking surfaces of the table top appliances. Air is filtered through the top of the appliance and released at the base. The self-contained air-filtration system is equipped with 3 filters, a dishwasher safe mechanical filter with a fine-meshed metal filter and a carbon activated filter. Large glass top suited for placing dishes to serve customers. Electrical plugs protected by covering plates. Side supports each holding n.2 GN 1/9 containers. Mounted on 4 swivelling wheels (two with brake). Rounded edges and smooth surfaces for easier cleaning. Cord and plug included. Optional accessories: drawers, tilting side shelves and customized front panels can be ordered on request.

APPROVAL: _____

Main Features

- Technological 3-stage filtering system composed of: a mechanical labyrinth filter for bigger particles of grease and steam, a mesh (metallic net) filter and carbon activated filters to absorb residual humidity and odors.
- Can accommodate up to two Libero Line tabletop appliances.
- Compact, lightweight and easy to move.
- Mounted on 4 swiveling wheels.
- Push open optional neutral drawers for additional storage space.
- Integrated variable speed fan ventilation system with multi-step filter solution to reduce cooking odors and steam from the cooking surfaces of the tabletop appliances.
- Rounded edges and smooth surfaces to facilitate cleaning operations.
- IP24 protected.

Construction

- Heavy duty Stainless steel construction.
- Glass side splash guards and stainless steel front serving shelf.
- Side supports to hold GN 1/9 container.

Included Accessories

- 1 of Support for containers (LP2 - HP) PNC 650067
- 1 of Central support for containers (LP2 & LP3 - HP) PNC 650068
- 3 of Carbon filter PNC 650069
- 2 of Labyrinth filter with stainless steel grid PNC 650072

Optional Accessories

- Tilting side shelf for Libero Point PNC 650005
- Top neutral drawer for Libero point PNC 650030
- Bottom neutral drawer for Libero point PNC 650033
- Support for containers (LP2 - HP) PNC 650067
- Central support for containers (LP2 & LP3 - HP) PNC 650068
- Carbon filter PNC 650069
- Labyrinth filter with stainless steel grid PNC 650072



Electrolux
PROFESSIONAL

Libero Line Series Libero Point, 2 HP unit freestanding counter

Front

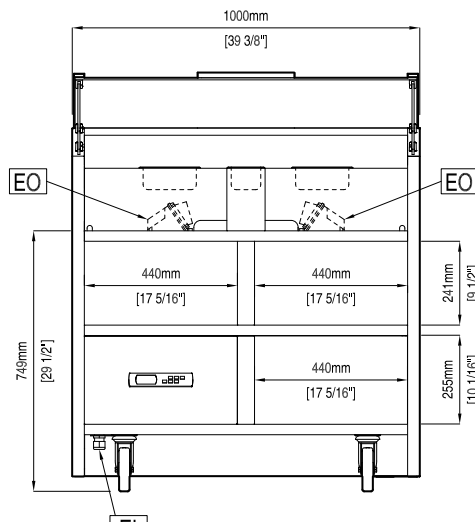

Side

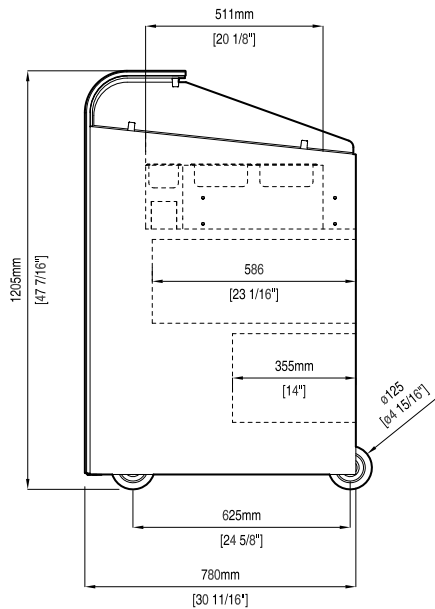

EI = Electrical inlet (power)
EO = Electrical Outlet

Top

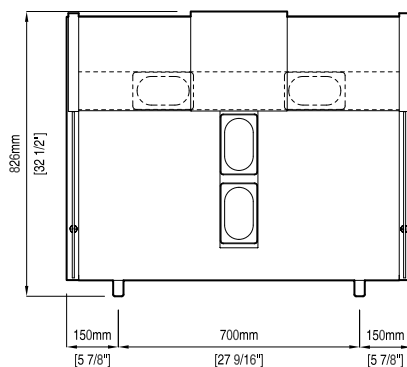

Electric

Supply voltage:

351061 (NELP2HP) 400 V/3N ph/50 Hz

Electrical power max.:

0.3 kW

Plug type:

IEC/EN 60309-1/2

Minimum Circuit Ampacity
(MCA):

32A

Key Information:

Aspiration capacity:

Speed level 8: 370 m³/h

Speed level 10: 550 m³/h

External dimensions, Width: 1000 mm

External dimensions, Height: 1204 mm

External dimensions, Depth: 780 mm

Net weight: 100 kg

Induction cooktop, Infrared cooktop, Induction wok and
Griddle.

Frontal power sockets

available for Plug-in Units:

- n° 2 CE plugs (3ph) & n°
2 Schuko plugs (1ph)/i

Libero Line Series
Libero Point, 2 HP unit freestanding counter

The company reserves the right to make modifications to the products
without prior notice. All information correct at time of printing.

2020.03.04

