

Modular Cooking Range Line 700XP Electric Tilting Bratt Pan 60lt with Duomat bottom

ITEM # _____

MODEL # _____

NAME # _____

SIS # _____

AIA # _____

371183 (E7BREHDNFX)

 60-lt electric tilting Braising
 Pan with duomat cooking
 surface

Short Form Specification

Item No. _____

Infrared heating elements positioned under the cooking surface. Duomat cooking surface for roasting, browning, stewing, preparation of sauces, sautéing, boiling and braising. Can be installed on cantilever systems. Installation on wheels is not available. Mechanism to manually tilt the pan. Double-skinned lid in stainless steel. Cooking temperature can be set through thermostat. Exterior panels in stainless steel with Scotch Brite finish. Height adjustable feet in stainless steel. Right-angled side edges to allow flush-fitting junction between units.

Main Features

- Infrared heating elements mounted below the cooking surface.
- Actual cooking temperature setting through adjustable thermostat.
- Working temperature can be set from 120 °C to 280 °C.
- Heat-insulated: limited heat radiation and low energy consumption.
- Manual tilting mechanism to facilitate pan emptying.
- Smooth large surfaces, easy access for cleaning.
- Unit to have stainless steel feet with height adjustment up to 50 mm.

Construction

- Cooking surface with Duomat bottom: a 10 mm-thick alloy obtained from the combination of 2 different stainless steels for better thermal stability and corrosion resistance.
- Lid in stainless steel to reduce heat dispersion.
- All pan internal surfaces round and polished for better hygiene.
- All exterior panels in Stainless Steel with Scotch Brite finishing.
- One piece pressed 1.5 mm work top in Stainless steel.
- Model has right-angled side edges to allow flush fitting joints between units, eliminating gaps and possible dirt traps.
- Usable capacity of the well 50 liters.
- IPx4 water protection.

APPROVAL: _____

Optional Accessories

- Flanged feet kit PNC 206136
- Frontal kicking strip for concrete installation, 800mm PNC 206148
- Frontal kicking strip for concrete installation, 1000mm PNC 206150
- Frontal kicking strip for concrete installation, 1200mm PNC 206151
- Frontal kicking strip for concrete installation, 1600mm PNC 206152
- Frontal kicking strip, 800mm (not for refr-freezer base) PNC 206176
- Frontal kicking strip, 1000mm (not for refr-freezer base) PNC 206177
- Frontal kicking strip, 1200mm (not for refr-freezer base) PNC 206178
- Frontal kicking strip, 1600mm (not for refr-freezer base) PNC 206179
- Kit 4 feet for concrete installation (not for 900 line free standing grill) PNC 206210
- Pair of side kicking strips PNC 206249
- Pair of side kicking strips for concrete installation PNC 206265
- Rear paneling - 800mm (700/900) PNC 206374
- Rear paneling - 1000mm (700/900) PNC 206375
- Rear paneling - 1200mm (700/900) PNC 206376
- Trolley with lifting & removable tank PNC 922403

Front

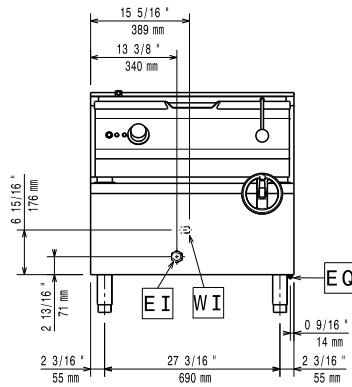

Side

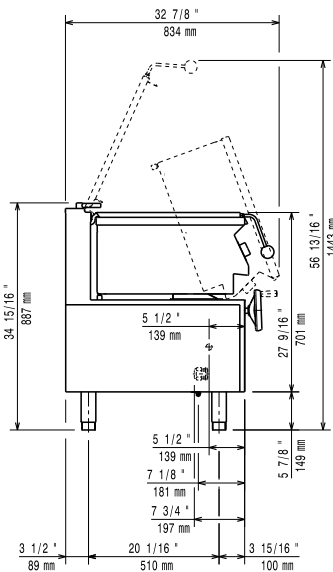

CW11 = Cold Water inlet 1 (cleaning)
 EI = Electrical inlet (power)

Top

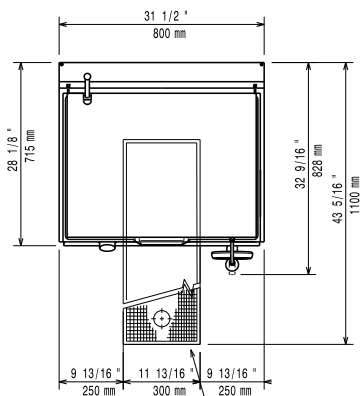

Electric

Supply voltage:	371183 (E7BREHDNFX)	380-400 V/3N ph/50/60 Hz
Total Watts:		9.5 kW
		380-400V 3N- 50/60Hz
Predisposed for:		8.6-9.5kW

Key Information:

Cooking Surface Depth:	410 mm
Cooking Surface Width:	680 mm
Cooking Surface Thickness:	10 mm
Cooking Well Height:	200 mm
Well Capacity, Max:	60 lt
Working Temperature MIN:	120 °C
Working Temperature MAX:	280 °C
External dimensions, Width:	800 mm
External dimensions, Height:	850 mm
External dimensions, Depth:	730 mm
Net weight:	105 kg
Shipping weight:	131 kg
Shipping height:	1080 mm
Shipping width:	820 mm
Shipping depth:	860 mm
Shipping volume:	0.76 m ³

No clearance needed on rear sides of unit if wall is of non combustible type. If wall is combustible, minimum 50 mm wall clearance should be maintained.

Certification group: N7BRE