

**Modular Cooking Range Line
 700XP 400mm Electric Fry Top, Smooth
 Brushed Chrome Horizontal Plate**

ITEM # _____

MODEL # _____

NAME # _____

SIS # _____

AIA # _____



371328 (E7IINDAOMCA) Half module electric Fry Top with smooth brushed chrome cooking Plate, horizontal, thermostatic control, scraper and sTopper included

Short Form Specification

Item No. _____

To be installed on open base installations or bridging supports. Smooth horizontal cooking surface in brushed chrome. Temperature range from 120°C to 280°C. Removable drawer below the cooking surface for the collection of grease and fat. Exterior panels in stainless steel with Scotch Brite finish. One piece pressed work top in 1.5 mm thick stainless steel. Right-angled side edges to allow flush-fitting junction between units.

Main Features

- Unit to be mounted on open base cupboards, bridging supports or cantilever systems.
- Large drain hole on cooking surface permits the draining of fat into large 1 liter collector placed under the cooking surface.
- Large grease collection container available as optional accessory to be installed under top units over open base cupboard.
- Safety thermostat and thermostatic control.
- Stainless steel high splash guard on the rear and sides of cooking surface. Splash guard can be easily removed for cleaning.
- IPx4 water protection.
- Frontal simmering zone.
- Temperature range from 120° up to 280°C.
- Infrared heating elements mounted below the cooking surface.
- Rough brushed chrome surface is highly resistant to scratches and facilitates cleaning operations at the end of the day.
- Scraper for smooth plate included as standard.

Construction

- Cooking surface completely smooth.
- All exterior panels in Stainless Steel with Scotch Brite finishing.
- One piece pressed 1.5 mm work top in Stainless steel.
- Model has right-angled side edges to allow flush fitting joints between units, eliminating gaps and possible dirt traps.
- Cooking surface 12mm thick brushed chrome for optimum grilling results and ease of use.

APPROVAL: _____

Included Accessories

- 1 of Scraper for smooth plate fry tops PNC 164255
- 1 of Stopper for fry top with horizontal plate PNC 206296

Optional Accessories

- Scraper for smooth plate fry tops PNC 164255
- Junction sealing kit PNC 206086
- Support for bridge type installation, 800mm PNC 206137
- Support for bridge type installation, 1000mm PNC 206138
- Support for bridge type installation, 1200mm PNC 206139
- Support for bridge type installation, 1400mm PNC 206140
- Support for bridge type installation, 1600mm PNC 206141
- Support for bridge type installation, 400mm PNC 206154
- Chimney upstand, 400mm PNC 206303
- Right and left side handrails PNC 206307
- Back handrail 800mm, Marine PNC 206308
- Grease/oil kit container for 700 line frytops (half and module) and 900 line frytops (module) PNC 206346
- Chimney grid net, 400mm (700XP/900) PNC 206400
- Frontal handrail, 400mm PNC 216046
- Frontal handrail, 800mm PNC 216047
- Frontal handrail, 1200mm PNC 216049
- Frontal handrail, 1600mm PNC 216050
- Large handrail - portioning shelf, 400mm PNC 216185
- Large handrail - portioning shelf, 800mm PNC 216186
- 2 side covering panels for top appliances PNC 216277

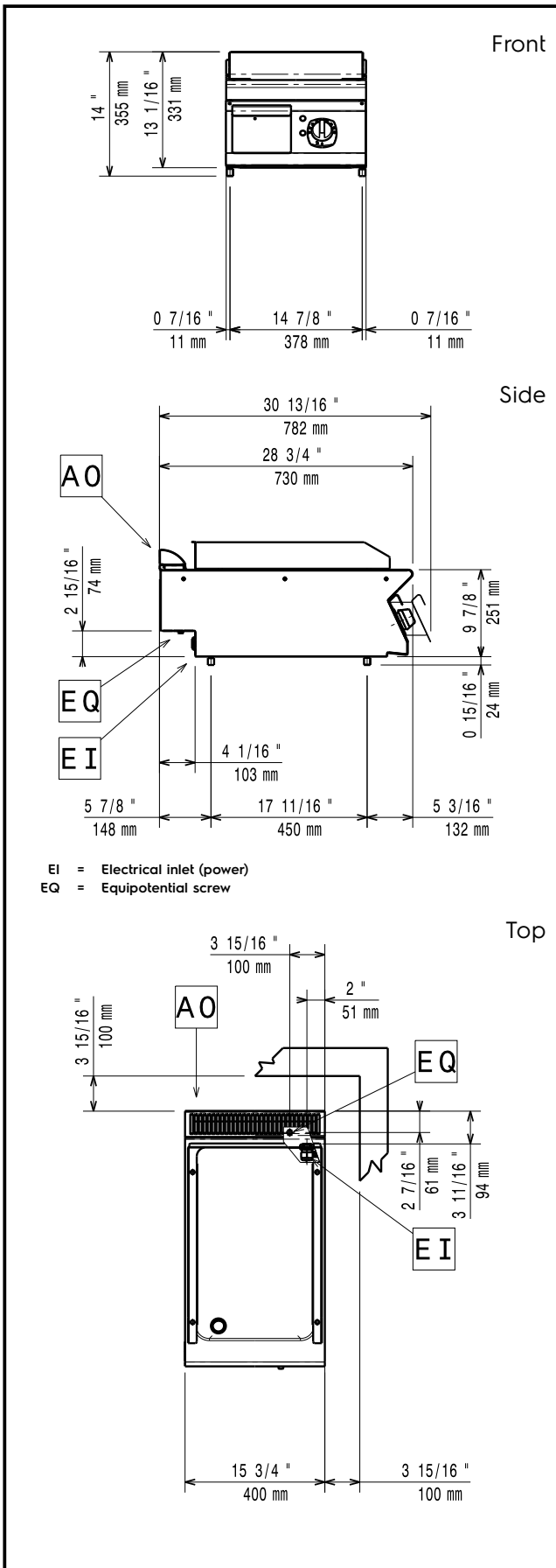

Electric

Supply voltage:	371328 (E7IINDAOMCA)	400 V/3 ph/50/60 Hz
Electrical power max.:		4.2 kW
Total Watts:		4.2 kW
Predisposed for:		380-400V 3~ 50/60Hz 3.8-4.2kW

Key Information:

Cooking surface width:	330 mm
Cooking surface depth:	540 mm
Working Temperature MIN:	120 °C
Working Temperature MAX:	280 °C
External dimensions, Width:	400 mm
External dimensions, Height:	250 mm
External dimensions, Depth:	730 mm
Net weight:	40 kg
Shipping weight:	40 kg
Shipping height:	530 mm
Shipping width:	460 mm
Shipping depth:	820 mm
Shipping volume:	0.2 m ³

If appliance is set up or next to or against temperature sensitive furniture or similar, a safety gap of approximately 150 mm should be maintained or some form of heat insulation fitted.