

# MKF 664 TS



## Electric combi oven with touch screen 6 trays 600 x 400 mm

### Plus

Patented fan guard system <b>Airflowlogic™</b>	
Patented system for direct steam <b>Humilogic™</b>	
Patented system for cooking chamber drying <b>Drylogic™</b>	
Available on request at the order	Voltage (V) : AC 220/230 3
	Left side opening door
Humidity management software	
Wi-Fi communication system	
Knob for quick selection of the touch screen	
Programmable oven start	
N° 40 recipes stored	
Control panel in 42 languages: Arabic, Armenian, Azerbaijani, Bahasa (Indonesia), Bahasa (Malaysia), Bosnian, Bulgarian, Chinese, Croatian, Czech, Danish, Dutch, English, Estonian, Finnish, French, Georgian, German, Greek, Hungarian, Icelandic, Italian, Japanese, Kazakh, Latvian, Lithuanian, Norwegian, Persian (Iran), Philippine, Polish, Portuguese, Romanian, Russian, Serbian, Slovenian, South Korean, Spanish, Swedish, Thai, Turkish, Ukrainian, Vietnamese	
HACCP system	
Adjustable door hinges	

All the space you need to give vent to your creativity in the kitchen is held in a medium-sized oven, which has great versatility. Thanks to the 6 trays measuring 600x400 mm, the two bi-directional motors and steam cooking, you can diversify the cooking of leavened products and fine pastry products to achieve the best taste. Everything is handled with a simple touch directly on the new TFT 7" 800x480 capacitive colour touch screen! The technological evolution of MILLENNIAL ovens to enhance the quality of your dishes.

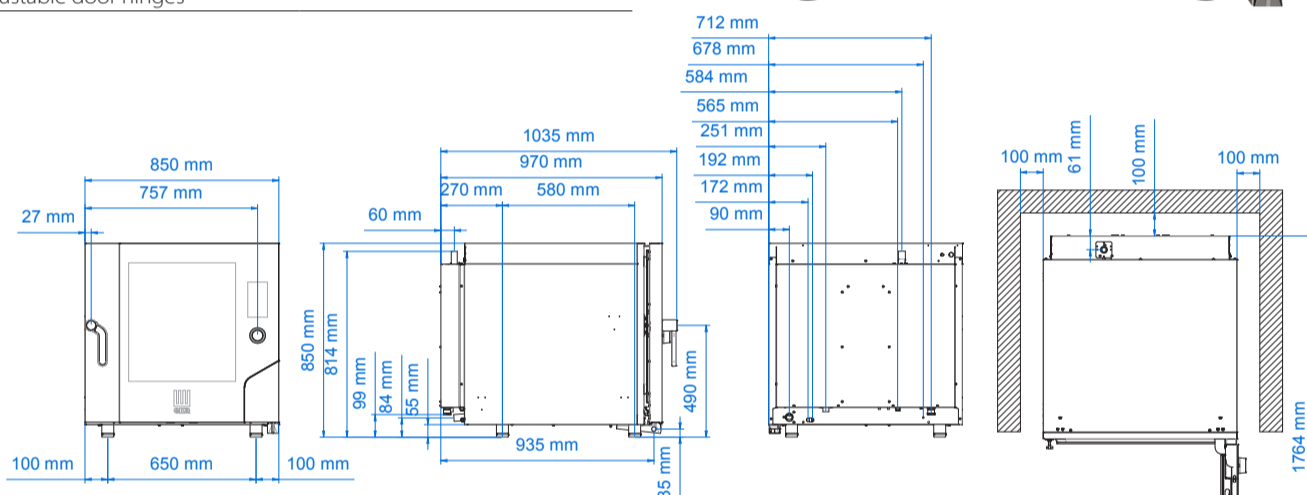
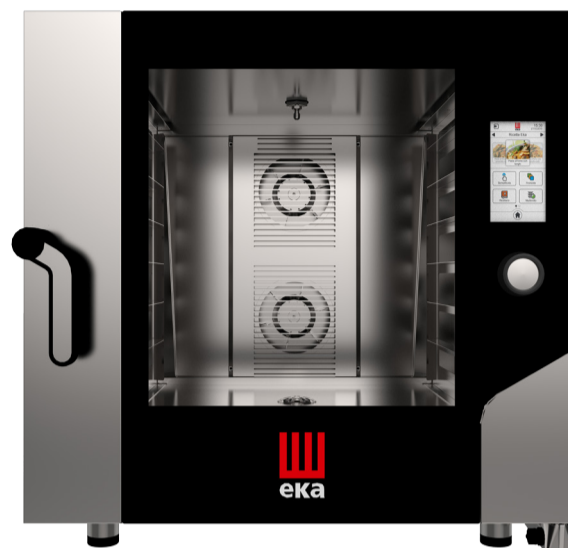

### Equipment

Cardboard box dimensions with pallet (WxDxH mm)	910 x 1090 x 1015 mm
Lateral supports	1 right + 1 left
Cable	Three-phase+neutral [5G 2,5]-L=1600 mm
USB port	
Multipoint core probe cod. MKSCMU	
Automatic washing system integrated	
Condensate collection bowl, with drain on door	
Hinge with door locking for openings adjusted at 60°, 90°, 120°, 180°	

### Optionals

Aluminium tray 600 x 400 mm	KT9P/A
Perforated aluminium tray 600 x 400 mm	KTF8P/A
5 lanes perforated and corrugated aluminium tray 600 x 400 mm	KTF9P
5 lanes AISI 304 grid 600 x 400 mm	KG5CPX
Chromed grid 600 x 400 mm	KG9P
Uncoated food aluminium plate 600 x 400 mm	KPP64
Table	MKTS 64
Table for overlapping ovens	MKT 64 D
Proofer and holding cabinet	MKLM 1064
Condensation hood	MKKC 610
Kit for overlapping ovens	MKS 64
Kit for overlapping tables	MKST 664
Smoker	MKAF
Multi-point core probe	MKSCMU
Vacuum cooking core probe	MKSCSV
Support for core probe	MKSSC
Detergent and rinse aid	MKDET
Spray kit with support and tube	EKKD
Water softener	KAF

### Dimensional features

Dimensions (WxDxH mm)	850 x 1035 x 850
Weight (kg)	108
Distance between rack rails (mm)	80

### Electrical features

Power supply (kW)	11,4
Frequency (Hz)	50/60
Voltage (V)	AC 380/400 3N
N° motors	2 bidirectionals
Boiler (kW)	/
Protection against water	IPX5

### Functional features

Power	Electricity
Capacity	N° 6 trays/grids 600 x 400 mm
Type of cooking	Semistatic + ventilated
Steam	Direct steam controlled by touch screen (10 levels)
Cooking chamber	AISI 304 stainless steel
Temperature	30 - 270 °C
Temperature control	Digital probe thermometer
Control panel	Touch screen
N° programs	500
Programmable cooking steps	10
Pre-heating temperature	180 °C
Pre-heating function	Programmable
Door	Right side opening Ventilated Inspectionable glass
Modularity	Yes
Feet	Adjustable