



**Modular Cooking Range Line
700XP One Well Freestanding Gas
Tube Fryer 34 liter**

ITEM # _____

MODEL # _____

NAME # _____

SIS # _____

AIA # _____



**Modular Cooking Range Line
700XP One Well Freestanding Gas Tube Fryer 34 liter**



371072 (E7FRGHILFT)

34-lt gas tube Fryer free standing with 1 well and 2 baskets

Short Form Specification

Item No. _____

To be installed on height adjustable feet in stainless steel. High efficiency 27.5 kW tube burners in stainless steel. Gas tubes are inside the deep drawn well. Suitable for natural gas or LPG. Oil drains through a tap into a container under the well. Exterior panels in stainless steel with Scotch Brite finish. One piece pressed work top in 1.5 mm thick stainless steel. Right-angled side edges to allow flush-fitting junction between units.

Main Features

- Ideal for frying breaded, battered or floured foods in general.
- Unit to be mounted on 50mm height adjustable feet in stainless steel.
- Tube burners located inside the well avoid food particles burning or spoiling the oil, reducing its usability for fast heat up and quick temperature recovery during the cooking.
- Flame failure device on each burner.
- Overheat protection thermostat as standard on all units.
- Oil drains through a tap into a drainage container positioned under the well.
- All major compartments located in front of unit for ease of maintenance.
- Piezo spark ignition for added safety.
- Gas appliance supplied for use with natural or LPG gas, conversion jets supplied as standard.
- IPx4 water protection.
- Thermostatic regulation of oil temperature up to a maximum of 185 °C.
- The special design of the control knob system guarantees against water infiltration.
- Optional portable oil quality monitoring tool (code 9B8081) for efficient oil management.

Construction

- Interior of well with rounded corners for ease of cleaning.
- All exterior panels in Stainless Steel with Scotch Brite finishing.
- One piece pressed 1.5 mm work top in Stainless steel.
- Model has right-angled side edges to allow flush fitting joints between units, eliminating gaps and possible dirt traps.

APPROVAL: _____



Experience the Excellence
www.electroluxprofessional.com



Included Accessories

- 2 of Half size basket for 36lt free standing fryers PNC 921609

Optional Accessories

- Junction sealing kit PNC 206086
- Draught diverter, 150 mm diameter PNC 206132
- Matching ring for flue condenser, 150 mm diameter PNC 206133
- Kit 4 wheels - 2 swivelling with brake - it is mandatory to install Base support and wheels PNC 206135
- Flanged feet kit PNC 206136
- Frontal kicking strip for concrete installation, 800mm PNC 206148
- Frontal kicking strip for concrete installation, 1000mm PNC 206150
- Frontal kicking strip for concrete installation, 1200mm PNC 206151
- Frontal kicking strip for concrete installation, 1600mm PNC 206152
- Frontal kicking strip, 800mm (not for refr-freezer base) PNC 206176
- Frontal kicking strip, 1000mm (not for refr-freezer base) PNC 206177
- Frontal kicking strip, 1200mm (not for refr-freezer base) PNC 206178
- Frontal kicking strip, 1600mm (not for refr-freezer base) PNC 206179
- Kit 4 feet for concrete installation (not for 900 line free standing grill) PNC 206210
- Flue condenser for 1 module, 150 mm diameter PNC 206246
- Pair of side kicking strips PNC 206249
- Pair of side kicking strips for concrete installation PNC 206265
- Chimney upstand, 800mm PNC 206304
- Right and left side handrails PNC 206307
- Back handrail 800mm, Marine PNC 206308
- Door for open base cupboard PNC 206350
- Base support for feet or wheels - 800mm (700/900) PNC 206367
- Base support for feet or wheels - 1200mm (700/900) PNC 206368
- Base support for feet or wheels - 1600mm (700/900) PNC 206369
- Base support for feet or wheels - 2000mm (700/900) PNC 206370
- Rear paneling - 800mm (700/900) PNC 206374

- Rear paneling - 1000mm (700/900) PNC 206375
- Rear paneling - 1200mm (700/900) PNC 206376
- Chimney grid net, 400mm (700XP/900) PNC 206400
- 2 side covering panels for free standing appliances PNC 216000
- Half size basket for 36lt free standing fryers PNC 921609
- Full size basket for 36lt fryers PNC 921642
- Filter for fryer oil collection basin for 7lt, 14lt, 15lt free standing fryers PNC 921693
- Pressure regulator for gas units PNC 927225



Front

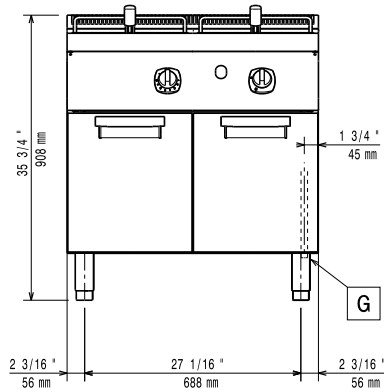

Side

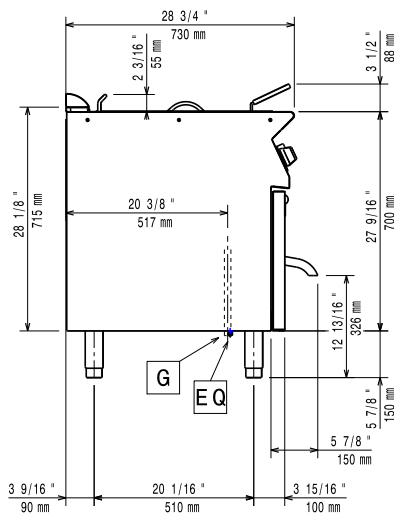

EQ = Equipotential screw
 G = Gas connection

Top

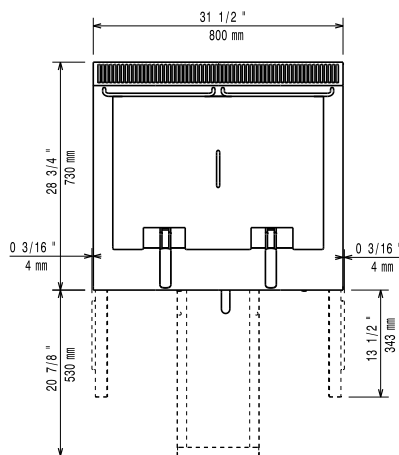

Gas

Gas Power:	371072 (E7FRGH1LFT)	27.5 kW
Standard gas delivery:		Natural Gas G20 (20mbar)
Gas Type Option:		LPG; Natural Gas
Gas Inlet:		1/2"

Key Information:

Usable well dimensions (width):	648 mm
Usable well dimensions (height):	380 mm
Usable well dimensions (depth):	320 mm
Well capacity:	29 lt MIN; 34 lt MAX
Thermostat Range:	105 °C MIN; 185 °C MAX
Net weight:	85 kg
Shipping weight:	94 kg
Shipping height:	1130 mm
Shipping width:	820 mm
Shipping depth:	860 mm
Shipping volume:	0.8 m ³

If appliance is set up or next to or against temperature sensitive furniture or similar, a safety gap of approximately 150 mm should be maintained or some form of heat insulation fitted.

Certification group: N7FG