



Modular Cooking Range Line 700XP One Well Electric Fryer Top 7 liter

ITEM # _____

MODEL # _____

NAME # _____

SIS # _____

AIA # _____



- 371075 (E7FRED1B00)** 7-lt electric Fryer Top with 1 "V" shape well (external heating elements) and 1 basket
- 371140 (E7FRED120N)** 7-lt electric Fryer Top with 1 "V" shape well (external heating elements) and 1 basket

Short Form Specification

Item No. _____

To be installed on open base installations, bridging supports or cantilever systems. High efficiency infrared heating elements (5.4kW) attached to the outside of the well. Deep drawn V-shaped well. Oil drains through a tap on the front. Exterior panels in stainless steel with Scotch Brite finish. One piece pressed work top in 1.5 mm thick stainless steel. Right-angled side edges to allow flush-fitting junction between units.

Main Features

- Unit to be mounted on open base cupboards, bridging supports or cantilever systems.
- Deep drawn V-Shaped well.
- High efficiency infrared heating elements (5,4kW) are attached to the outside of the well.
- Thermostatic regulation of oil temperature up to a maximum of 185 °C.
- Overheat protection thermostat as standard on all units.
- Oil drains through a tap positioned on the front the well.
- All major compartments located in front of unit for ease of maintenance.
- IPx4 water protection.
- Optional portable oil quality monitoring tool (code 9B8081) for efficient oil management.

Construction

- Interior of well with rounded corners for ease of cleaning.
- All exterior panels in Stainless Steel with Scotch Brite finishing.
- One piece pressed 1.5 mm work top in Stainless steel.
- Model has right-angled side edges to allow flush fitting joints between units, eliminating gaps and possible dirt traps.

APPROVAL: _____



Modular Cooking Range Line
700XP One Well Electric Fryer Top 7 liter



Included Accessories

- 1 of Basket for 7lt top and free standing fryers PNC 921608

Optional Accessories

- Junction sealing kit PNC 206086
- Support for bridge type installation, 800mm PNC 206137
- Support for bridge type installation, 1000mm PNC 206138
- Support for bridge type installation, 1200mm PNC 206139
- Support for bridge type installation, 1400mm PNC 206140
- Support for bridge type installation, 1600mm PNC 206141
- Support for bridge type installation, 400mm PNC 206154
- Chimney upstand, 400mm PNC 206303
- Right and left side handrails PNC 206307
- Back handrail 800mm, Marine PNC 206308
- Chimney grid net, 400mm (700XP/900) PNC 206400
- 2 side covering panels for top appliances PNC 216277
- Basket for 7lt top and free standing fryers PNC 921608
- 2 baskets for 2x5lt and 7lt electric fryers PNC 960638

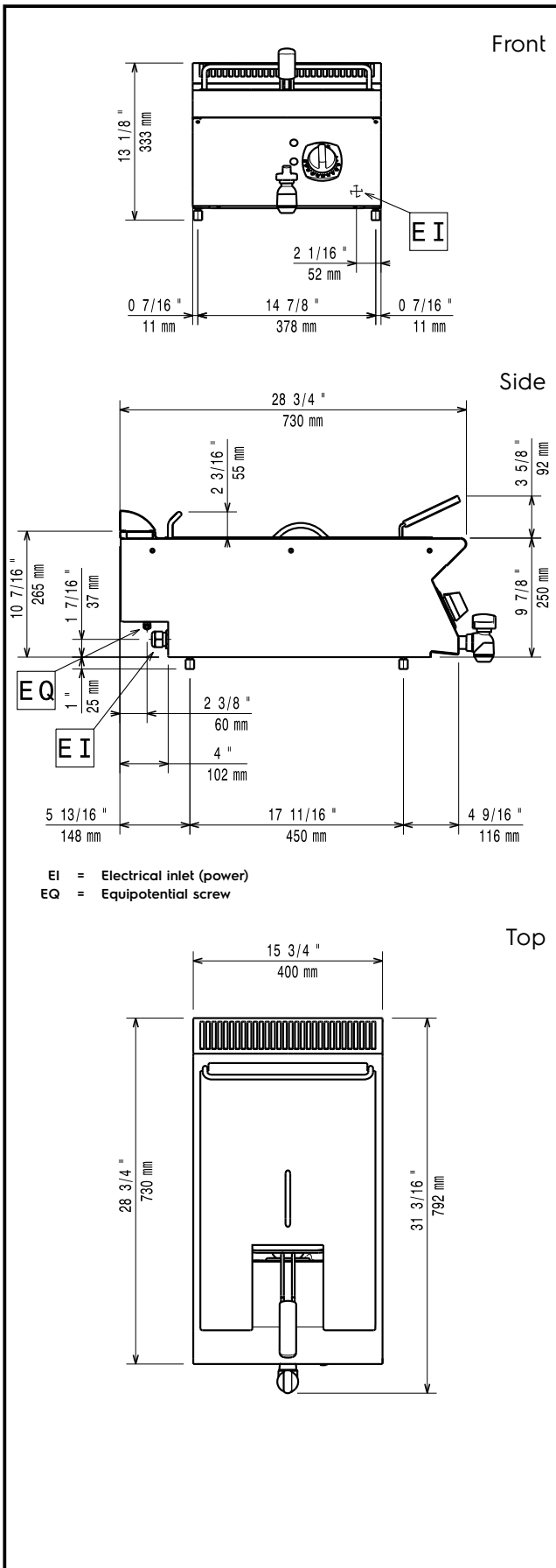

Electric

Supply voltage:

371075 (E7FRED1B00)	380-400 V/3N ph/50/60 Hz
371140 (E7FRED120N)	230 V/3 ph/50/60 Hz

Total Watts:

5.4 kW

Predisposed for:

371075 (E7FRED1B00)	380-400V 3N- 50/60Hz
	4,9-5,4kW

Key Information:

Usable well dimensions (width):

240 mm

Usable well dimensions (height):

235 mm

Usable well dimensions (depth):

380 mm

Well capacity:

5.5 lt MIN; 7 lt MAX

Thermostat Range:

105 °C MIN; 185 °C MAX

Net weight:

30 kg

Shipping weight:

371075 (E7FRED1B00)	29 kg
371140 (E7FRED120N)	35 kg

Shipping height:

371075 (E7FRED1B00)	520 mm
371140 (E7FRED120N)	540 mm

Shipping width:

460 mm

Shipping depth:

820 mm

Shipping volume:

0.2 m³

If appliance is set up or next to or against temperature sensitive furniture or similar, a safety gap of approximately 150 mm should be maintained or some form of heat insulation fitted.

Certification group:

371075 (E7FRED1B00)	N7FE1
371140 (E7FRED120N)	N7FE2