



**Electrolux**  
PROFESSIONAL

**Modular Cooking Range Line  
700XP Two Wells Freestanding  
Electric Fryer 7 liter**

ITEM # \_\_\_\_\_

MODEL # \_\_\_\_\_

NAME # \_\_\_\_\_

SIS # \_\_\_\_\_

AIA # \_\_\_\_\_



**371078 (E7FREH2BF0)**

7+7-lt electric Fryer free standing with 2 "V" shape wells (external heating elements) and 2 baskets

**371141 (E7FREH22FN)**

7+7-lt electric Fryer free standing with 2 "V" shape wells (external heating elements) and 2 baskets

**Short Form Specification**

**Item No.** \_\_\_\_\_

To be installed on height adjustable feet in stainless steel. High efficiency infrared heating elements (10.8kW) attached to the outside of the well. Deep drawn V-shaped well. Oil drains through a tap into a container under the well. Melting function to safely heat-up solid shortening used to fry products. Exterior panels in stainless steel with Scotch Brite finish. One piece pressed work top in 1.5 mm thick stainless steel. Right-angled side edges to allow flush-fitting junction between units.

**Main Features**

- Unit to be mounted on height adjustable feet in stainless steel.
- Deep drawn V-Shaped wells.
- High efficiency infrared heating elements are attached to the outside of the wells.
- Thermostatic regulation of oil temperature up to a maximum of 185 °C.
- Overheat protection thermostat as standard on all units.
- Oil drains through a tap into a drainage container positioned under the wells.
- All major compartments located in front of unit for ease of maintenance.
- IPx4 water protection.
- Optional portable oil quality monitoring tool (code 9B8081) for efficient oil management.

**Construction**

- All exterior panels in Stainless Steel with Scotch Brite finishing.
- One piece pressed 1.5 mm work top in Stainless steel.
- Model has right-angled side edges to allow flush fitting joints between units, eliminating gaps and possible dirt traps.
- Interior of well with rounded corners for ease of cleaning.

**Included Accessories**

- 2 of Door for open base cupboard PNC 206350
- 2 of Basket for 7lt top and free standing fryers PNC 921608

**Optional Accessories**

- Junction sealing kit PNC 206086
- Kit 4 wheels - 2 swivelling with brake - it is mandatory to install Base support and wheels PNC 206135
- Flanged feet kit PNC 206136
- Frontal kicking strip for concrete installation, 800mm PNC 206148
- Frontal kicking strip for concrete installation, 1000mm PNC 206150
- Frontal kicking strip for concrete installation, 1200mm PNC 206151
- Frontal kicking strip for concrete installation, 1600mm PNC 206152
- Frontal kicking strip, 800mm (not for refr-freezer base) PNC 206176

**APPROVAL:** \_\_\_\_\_



Experience the Excellence  
[www.electroluxprofessional.com](http://www.electroluxprofessional.com)

**700XP Two Wells Freestanding Electric Fryer 7 liter**  
Modular Cooking Range Line

- Frontal kicking strip, 1000mm (not for refr-freezer base) PNC 206177
- Frontal kicking strip, 1200mm (not for refr-freezer base) PNC 206178
- Frontal kicking strip, 1600mm (not for refr-freezer base) PNC 206179
- Kit 4 feet for concrete installation (not for 900 line free standing grill) PNC 206210
- Pair of side kicking strips PNC 206249
- Pair of side kicking strips for concrete installation PNC 206265
- Chimney upstand, 800mm (only for 371078) PNC 206304
- Right and left side handrails PNC 206307
- Back handrail 800mm, Marine PNC 206308
- Door for open base cupboard PNC 206350
- Base support for feet or wheels - 800mm (700/900) PNC 206367
- Base support for feet or wheels - 1200mm (700/900) PNC 206368
- Base support for feet or wheels - 1600mm (700/900) PNC 206369
- Base support for feet or wheels - 2000mm (700/900) PNC 206370
- Rear paneling - 800mm (700/900) PNC 206374
- Rear paneling - 1000mm (700/900) PNC 206375
- Rear paneling - 1200mm (700/900) PNC 206376
- Chimney grid net, 400mm (700XP/900) PNC 206400
- 2 side covering panels for free standing appliances PNC 216000
- Basket for 7lt top and free standing fryers PNC 921608
- Filter for fryer oil collection basin for 7lt, 14lt, 15lt free standing fryers PNC 921693
- 2 baskets for 2x5lt and 7lt electric fryers PNC 960638

Front

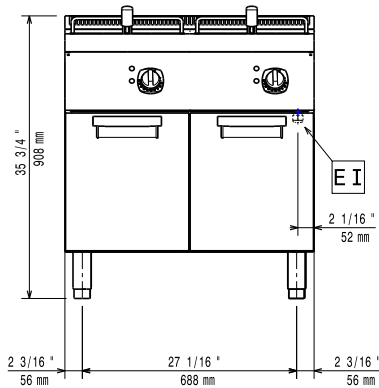

Side

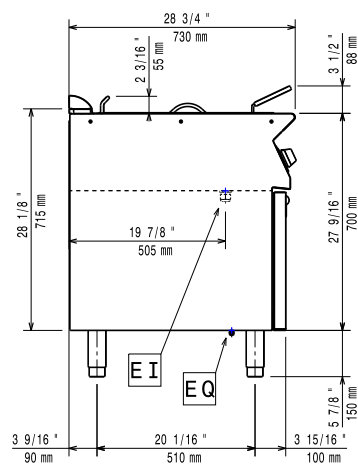

EI = Electrical inlet (power)  
 EQ = Equipotential screw

Top

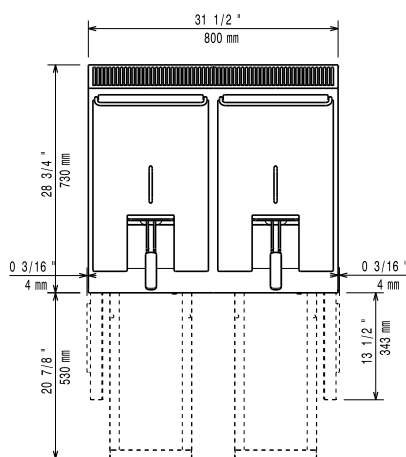

## Electric

### Supply voltage:

371078 (E7FREH2BF0) 380-400 V/3N ph/50/60 Hz  
 371141 (E7FREH22FN) 230 V/3 ph/50/60 Hz

### Total Watts:

10.8 kW

### Predisposed for:

371078 (E7FREH2BF0) 380-400V 3N- 50/60Hz  
 9,8-10,8kW

## Key Information:

Usable well dimensions  
 (width):

240 mm

Usable well dimensions  
 (height):

235 mm

Usable well dimensions  
 (depth):

380 mm

Well capacity:

5.5 lt MIN; 7 lt MAX

Thermostat Range:

105 °C MIN; 185 °C MAX

Net weight:

69 kg

Shipping weight:

81 kg

Shipping height:

371078 (E7FREH2BF0) 1130 mm  
 371141 (E7FREH22FN) 1140 mm

Shipping width:

820 mm

Shipping depth:

860 mm

Shipping volume:

0.8 m<sup>3</sup>

If appliance is set up or next to or against temperature sensitive furniture or similar, a safety gap of approximately 150 mm should be maintained or some form of heat insulation fitted.

### Certification group:

371078 (E7FREH2BF0) N7FE1  
 371141 (E7FREH22FN) N7FE2