

CS-200

Hot Food Holding Carving Station

ALTO-SHAAM

Alto-Shaam carving stations keep food fresh, hot and ready to serve at just the right temperature. Maximize visual appeal while maintaining food temperature and quality. Gentle, precise Halo Heat® technology radiates directly from the carving shelf surface, while ambient surface lamps keep food warm without cooking or drying out food.



CS-200/S

Standard Features

- Controlled, uniform holding with Halo Heat technology
- Fixed lamp assembly provides additional heat to the product for greater surface temperature control
- NSF- and USDA-listed removable cutting board with integrated gravy lane
- Recessed heated surface to catch drippings
- Heated base provides low, medium or high heat options
- Designed to fit on top of Cook & Hold Ovens, heated holding cabinets, smoker ovens or suitable for placement on any surface
- Optional clear-glass customer breath guard easily slides in place, meeting NSF breath guard specification

Configurations (select one)

- CS-200 CS-200/S

Electrical

- 120V 230V

Accessories (select all that apply)

Cutting board

- Full size: 21-5/5" x 21-5/8" x 1/2" [550mm x 550mm x 13mm] [BA-28066]
 Half size: 10-3/4" x 21-5/8" x 1/2" [273mm x 550mm x 13mm] [BA-29244]

Carving Holders

- Prime rib [HL-2635]
 Steamship round [4459]



70 lb [32 kg] product maximum



CS-200

Specification

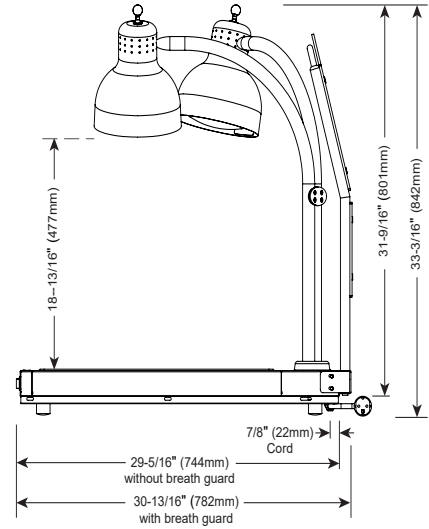
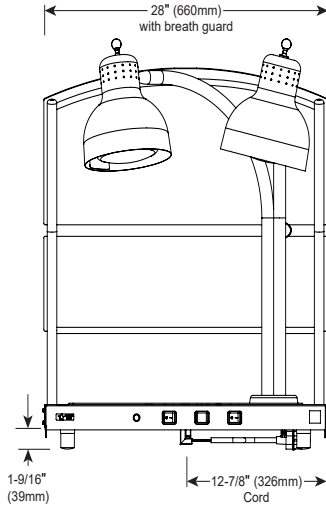
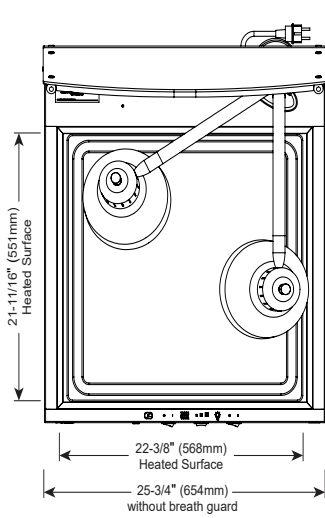

DIMENSIONS

Model

CS-200
CS-200/S

Exterior (H x W x D)

33-3/16" x 25-3/4" x 29-5/16" [842mm x 654mm x 744mm]
33-3/16" x 26" x 30-13/16" [842mm x 660mm x 782mm]

Net Weight

60 lb [27 kg]
Contact factory

Ship Weight*

CS-200 150 lb [68 kg]
CS-200/S 170 lb [77 kg]

Ship Dimensions (L x W x H)*

35" x 35" x 41" [889mm x 889mm x 1041mm]
35" x 35" x 41" [889mm x 889mm x 1041mm]

*Domestic ground shipping information. Contact factory for export weight and dimensions.



CHECK FIRST

- Appliance must be installed on a stable level surface.
- Appliance must not be installed in any area where it may be affected by steam, grease, dripping water, high temperatures, or any other severely adverse conditions.
- Warranty does not apply if the carving station is flooded or immersed in water.



ELECTRIC

CS-200	V	Ph	Hz	A	kW	Cord & Plug
120V	120	1	60	6.3	0.75	NEMA 5-15p 15A-125V plug
230V	230	1	50/60	3.26	0.75	Plugs rated 250V CEE 7/7 CH2-16P BS 1363 AS/NZS 3112

CONTACT US

W164 N9221 Water Street | Menomonee Falls, Wisconsin 53051 | U.S.A.
Phone: 262.251.3800 | 800.558.8744 U.S.A./Canada | Fax: 262.251.7067 | alto-shaam.com