

Vector® H Series Multi-Cook Oven

CE Certified

ALTO-SHAAM

Providing an unmatched volume and variety of food, compact and ventless Vector H Series countertop models are specifically designed for foodservice operations where space is at a premium, but food demand is high.

Featuring up to four independent oven chambers, operators can control the temperature, fan speed and cook time in each individual chamber for maximum flexibility – simultaneously cooking a variety of menu items with no flavor transfer.

Exclusive Structured Air Technology® delivers focused heat for faster, more even cooking and consistent, high-quality results.

Reduce labor by eliminating extra steps in food production and the need to watch and rotate pans.

Place anywhere with a small, 533mm footprint and ventless, waterless operation.

An advanced control – designed intentionally simple – features an intuitive, user-friendly interface and programmable recipes to ensure consistency with each cook.

Custom colors available for enhanced branding and a front-of-house experience for customers.

ISO 9001:2015-certified



VMC-H4H

VMC-H3H

VMC-H2H

Configurations (select one)

Models

These models accommodate a full-size hotel pan

- VMC-H2H
- VMC-H3H
- VMC-H4H

Control

- Deluxe
- Simple

Door swing

- Right hinged
- Left hinged

Electrical

VMC-H2H

- 220–240V, 1PH, no cord, no plug
- 380–415V, 3PH, no cord, no plug

VMC-H3H

- 220–240V, 1PH, no cord, no plug
- 380–415V, 3PH, no cord, no plug

VMC-H4H

- 380–415V, 3PH, no cord, no plug

Accessories (select all that apply)

Casters and Legs

- 76mm casters, set of four (4) (5027946)

Cookware

- Jet plate assembly, hotel pan (5025236)
- Wire rack (SH-37662)
- Wire shelf, hotel pan (SH-39077)
- Wire shelf, hotel pan w/pan holder (SH-39543)
- Fry basket (BS-46316)
- Fry basket 325mm x 529mm (BS-26730)(Available for HxH models only)

Cleaning

- EcoLab® Greaselift®, case of six (6) bottles (CE-39136)
- ChemCo Dirt Buster III, case of six (6) bottles (CE-39137)

Grease Filters

- Internal chamber filters—order one (1) kit per chamber (5027119)

Standard Features

- Programmable, touchscreen control
- Easy recipe upload/download via USB port
- Double-pane glass door
- One (1) wire stainless steel rack and two (2) jet plates per cooking chamber
- 102mm adjustable legs



- 2 VMC-H2H: 2 shelf, 2 GN 1/1—530mm x 325mm x 100mm or 2 GN 2/3 pans—354 mm x 325 mm x 25 mm
- 3 VMC-H3H: 3 shelf, 3 GN 1/1—530mm x 325mm x 100mm or 3 GN 2/3 pans—354 mm x 325 mm x 25 mm
- 4 VMC-H4H: 4 shelf, 4 GN 1/1—530mm x 325mm x 100mm or 4 GN 2/3 pans—354 mm x 325 mm x 25 mm

Vector® H Series Multi-Cook Oven

Specification

ALTO-SHAAM

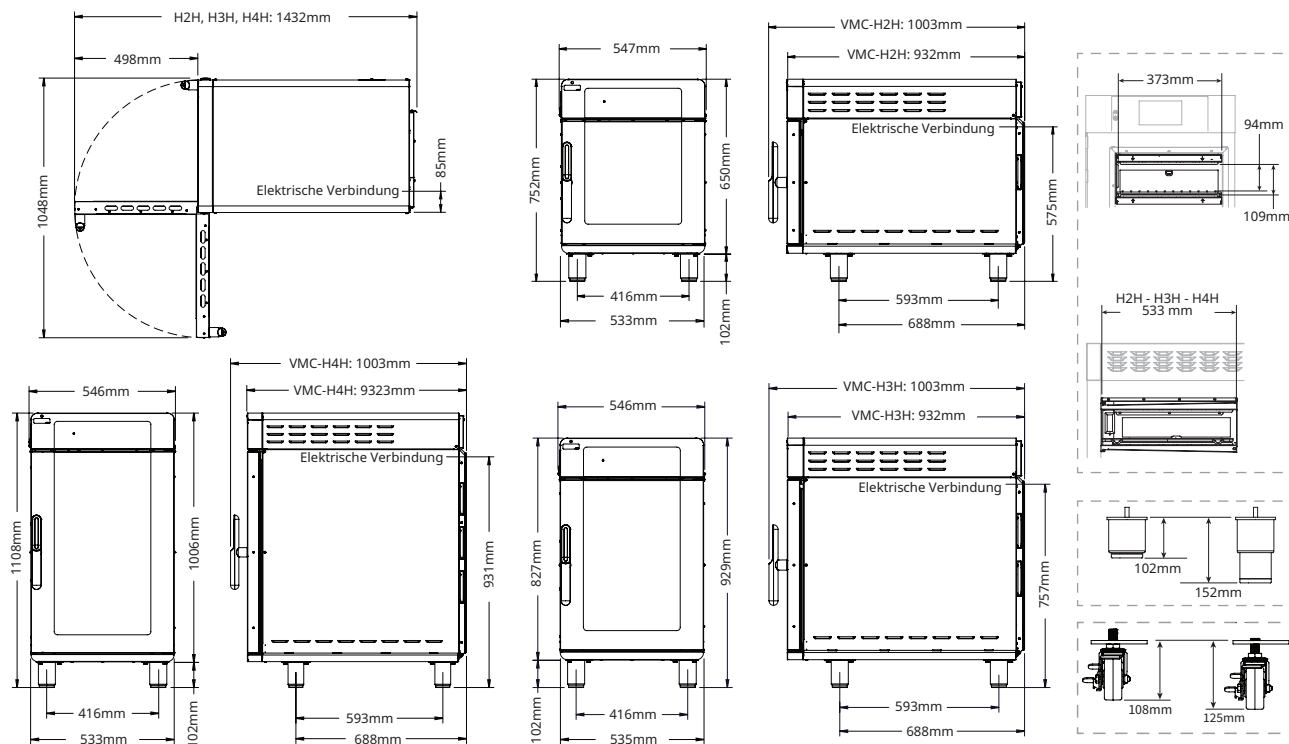

DIMENSIONS

Model	Exterior (H x W x D)
VMC-H2H	752mm x 546mm x 1003mm
VMC-H3H	929mm x 546mm x 1003mm
VMC-H4H	1108mm x 546mm x 1003mm

Interior (H x W x D)
366mm x 373mm x 546mm
544mm x 373mm x 546mm
721mm x 373mm x 546mm

Net Weight
97 kg
126 kg
158 kg

Chamber Height

109mm

Model	Ship Dimensions (L x W x H)*
VMC-H2H	1219mm x 737mm x 1422mm
VMC-H3H	1219mm x 737mm x 1422mm
VMC-H4H	1219mm x 737mm x 1422mm

Ship Weight*
132 kg
170 kg
193 kg

*Domestic ground shipping information. Contact factory for export weight and dimensions.



CLEARANCE

Top:	51mm
Left:	51mm
Right:	51mm
Front:	51mm
Back:	51mm



CHECK FIRST

- The oven must be installed level.
- The oven must not be installed in any area where it may be affected by steam, grease, dripping water, high temperatures, or any other severely adverse conditions.
- Oven not intended for built-in installation.

Vector® H Series Multi-Cook Oven



Heat of rejection

VMC-H	Heat Gain qs, BTU/hr	Heat Gain qs, kW
	1,898	0.56



Maximum temperature: 274°C

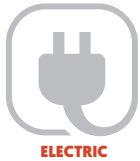

VMC-H2H	V	Ph	Hz	IEC	A	Breaker [A]	kW	Plug Configuration	Certification
220-240V	220	1	50/60	4	25	32	5.4	No cord, no plug	CE EAC IP X4
	240	1	50/60	4	28	32	6.4	No cord, no plug	
380-415V	380	3	50/60	1.5	12	16	5.4	No cord, no plug	CE EAC IP X4
	415	3	50/60	1.5	13	16	6.4	No cord, no plug	
VMC-H3H									
220-240V	220	1	50/60	10	37	63	8.1	No cord, no plug	CE EAC IP X4
	240	1	50/60	10	41	63	9.6	No cord, no plug	
380-415V	380	3	50/60	1.5	12	16	8.1	No cord, no plug	CE EAC IP X4
	415	3	50/60	1.5	13	16	9.6	No cord, no plug	
VMC-H4H									
380-415V	380	3	50/60	4	23	32	10.8	No cord, no plug	CE EAC IP X4
	415	3	50/60	4	25	32	12.7	No cord, no plug	

Vector® H Series Multi-Cook Oven



Stacked Configurations and Stands

VMC-H2H, VMC-H3H, or VMC-H4H on stand 5028223

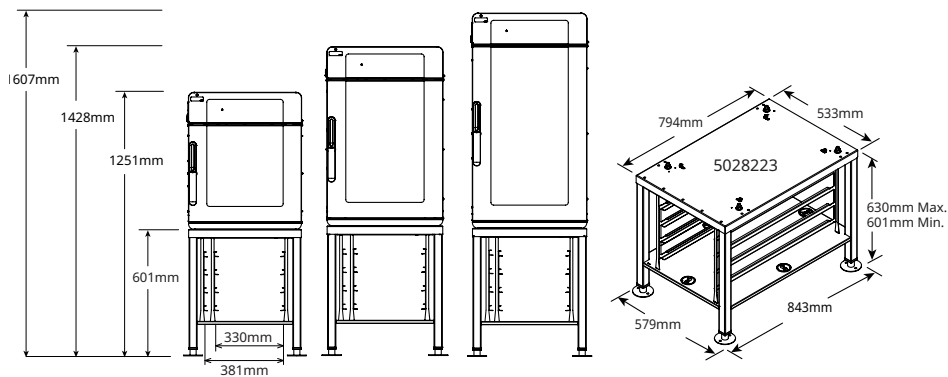

Dimensions shown are with adjustable feet at minimum height.

VMC-H2H, VMC-H3H, or VMC-H4H on stand 5028173

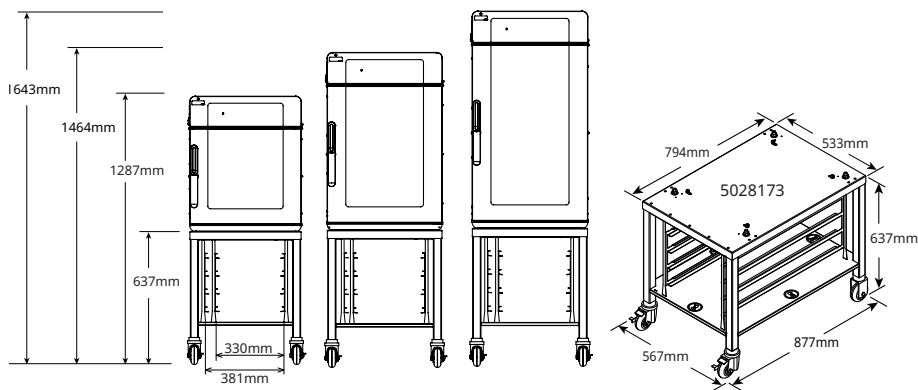

VMC-H2H, VMC-H3H or VMC-H4H on stand 5027644

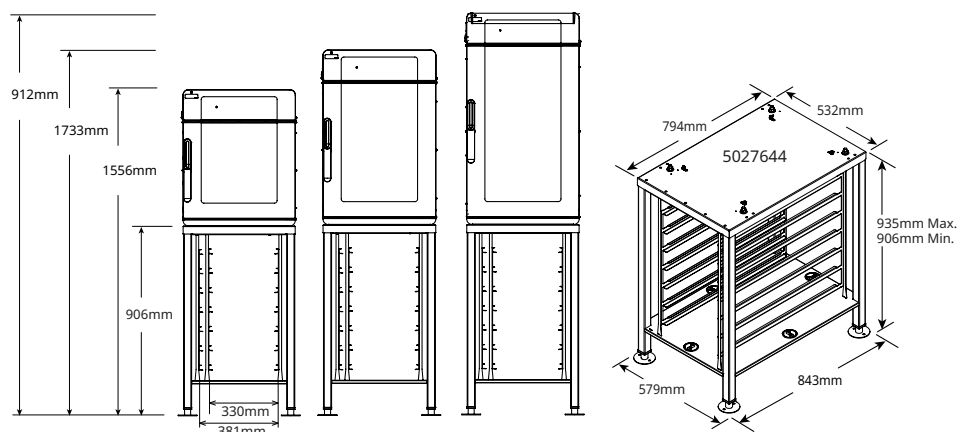

Dimensions shown are with adjustable feet at minimum height.

Vector® H Series Multi-Cook Oven



Stacked Configurations and Stands

VMC-H2H on stand 5027834 over VMC-H2H on stand 5030180 with casters

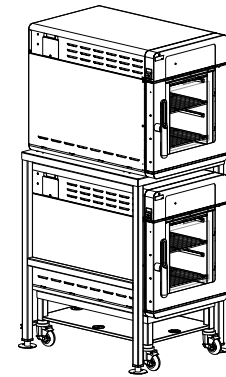
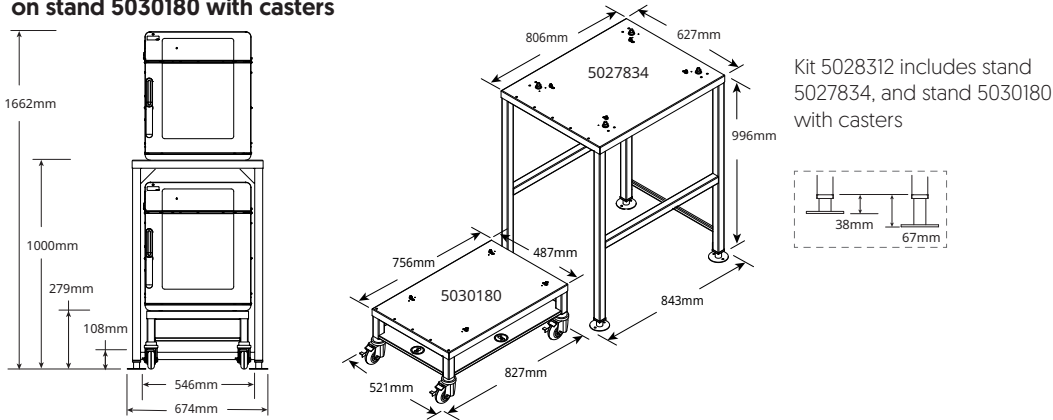

Dimensions shown are with adjustable feet at minimum height.

VMC-H2H, VMC-H3H, or VMC-H4H on stand 5027834 over VMC-H3H with casters

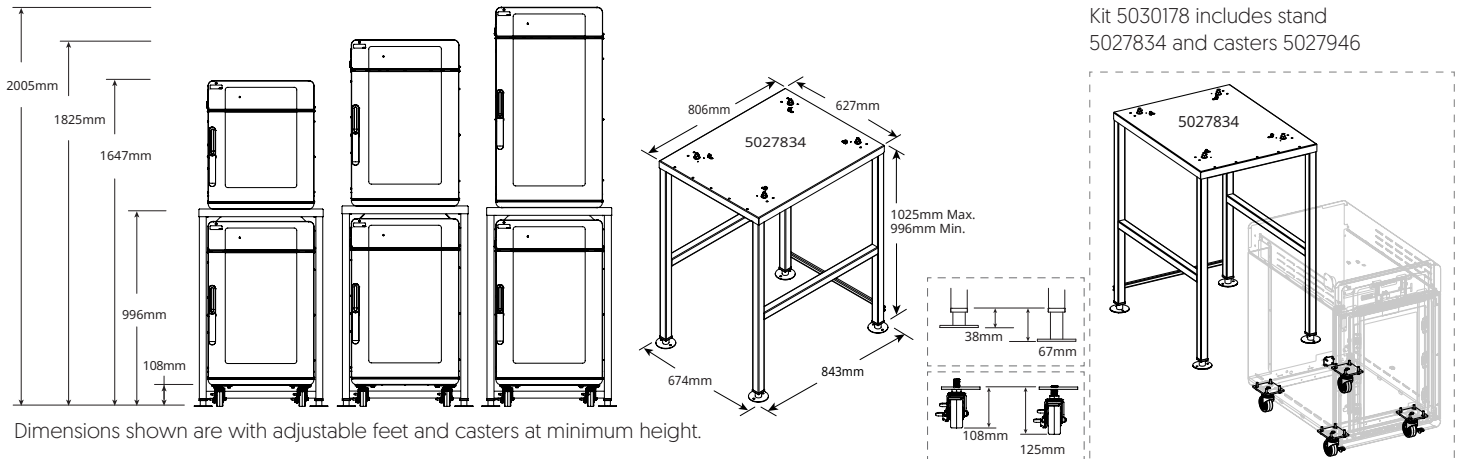

Dimensions shown are with adjustable feet and casters at minimum height.

VMC-H2H or VMC-H3H on stand 5027835 over VMC-H4H [a VMC-H4H cannot be stacked on top of this stand]

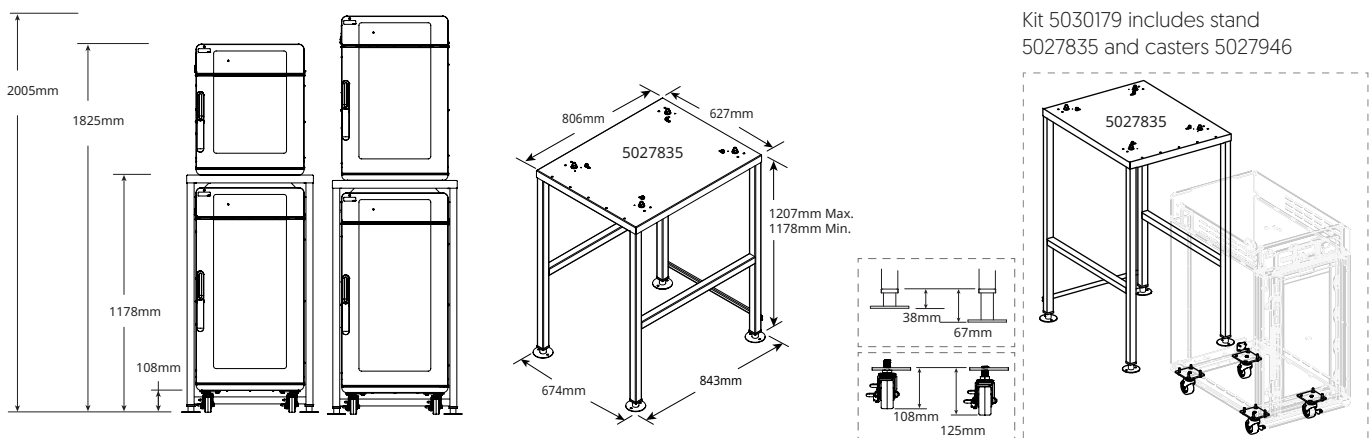

Dimensions shown are with adjustable feet and casters at minimum height.

Vector® H Series Multi-Cook Oven



Stacked Configurations and Stands

**VMC-H2H, VMC-H3H, or VMC-H4H on stand 5027762
over 750-S, 750-TH/II, 750-TH/III, or 767-SK/III***

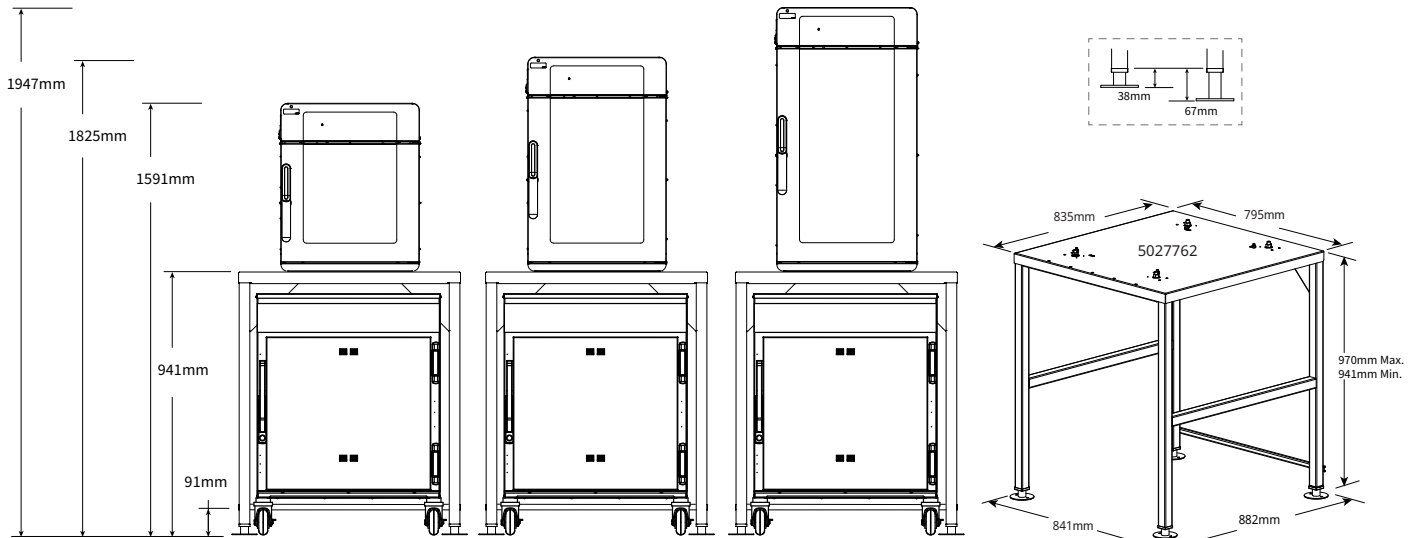

Dimensions shown are with adjustable feet at minimum height.
*Smoker models must be under a hood.

**VMC-H2H, VMC-H3H, or VMC-H4H on stand 5027834
over 500-S, 500-TH/II, or 500-TH/III**

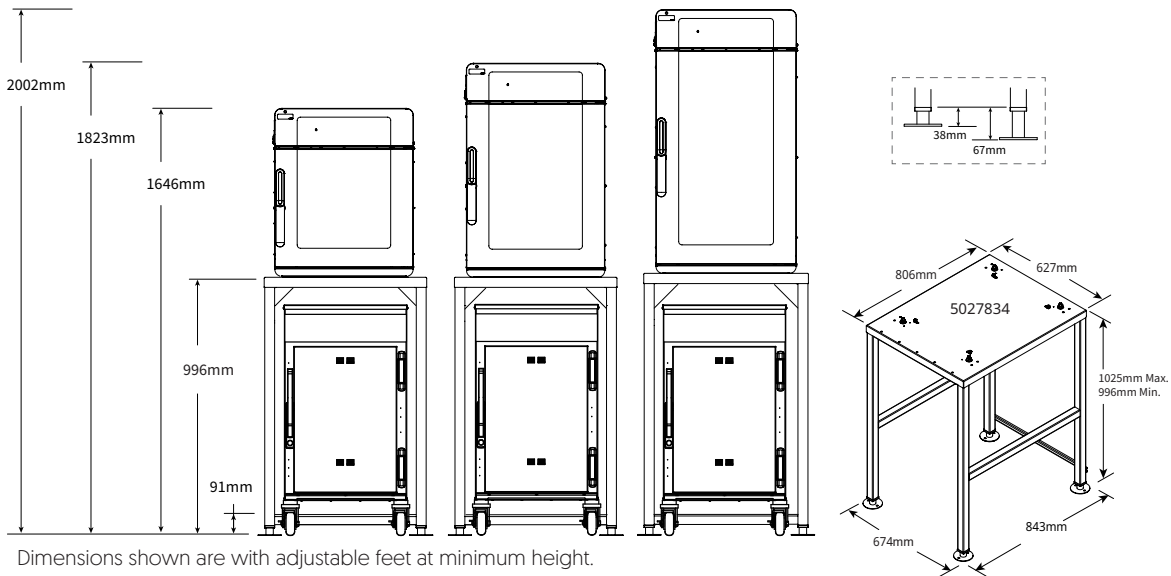

Dimensions shown are with adjustable feet at minimum height.

Vector® H Series Multi-Cook Oven



Alternative Stacked Configurations and Stands

CTX4-10 on stand 5028514 over VMC-H3H

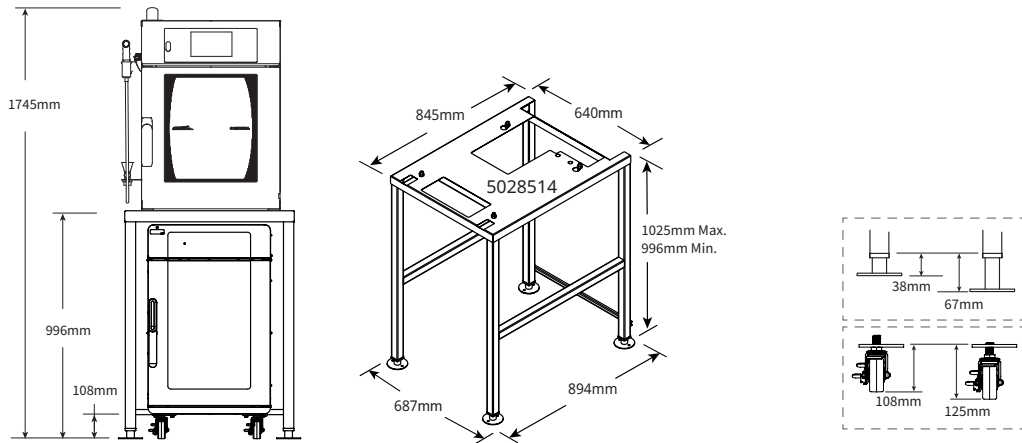

Dimensions shown are with adjustable feet and casters at minimum height.

CTX4-10 on stand 5028516 over VMC-H4H

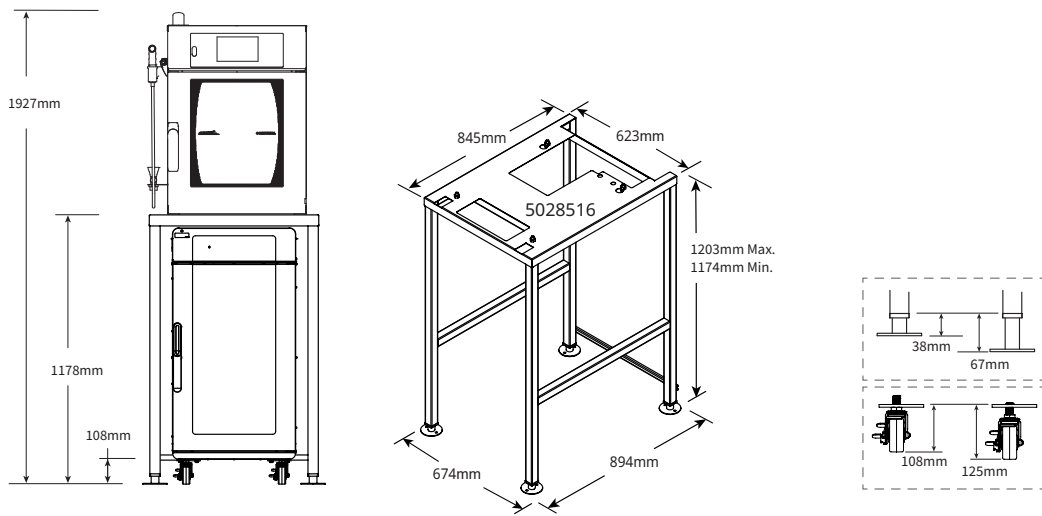

Dimensions shown are with adjustable feet and casters at minimum height.

CONTACT US

W164 N9221 Water Street | Menomonee Falls, Wisconsin 53051 | U.S.A.
Phone: 262.251.3800 | 800.558.8744 U.S.A./Canada | Fax: 262.251.7067 | alto-shaam.com