



## Technical Data Sheet

Code	Catalogue	Page
V080FTREVCRT	CATALOGUE	V064
HS Code	84198180	
Capacity	670x530 mm	

Dim. mm (WxDxH)	Energy	KW Total	Voltage	Phase	Frequency	N. Components	Nett. Weight kg
800 x 730 x 250		10,800	400	3F+N	50/60	1	71.70

**GB** Electric griddle, top version, 1/3 grooved plate and 2/3 smooth chromed plate

Side panels, bottom and back made in stainless steel. Top made in stainless steel AISI 304 15/10. Flue made in enamelled cast-iron. Recessed hotplate fully welded and sealed to the top. Cooking plate in glossy-chrome finishing. 10 mm sloping surface to easily collect grease. Extractable drawer for grease drain and collection. Heavy-duty heating elements. Cooking temperature monitored by thermostats. Equipped with safety thermostat. Special designed knobs to avoid water penetration in the control panel.

**I** Fry-top elettrico versione top, 1/3 rigata e 2/3 piastra liscia cromata

Fianchi, fondo e schienale in acciaio inox. Piano in acciaio inox AISI 304 15/10. Camino posteriore in ghisa smaltata. Piastra di cottura ribassata rispetto al piano di lavoro, saldata ermeticamente. Superficie rivestita con cromo duro lucidato a specchio. Piastra inclinata di 10 mm per facilitare la raccolta dei grassi. Cassetto raccolta grassi. Riscaldamento ottenuto con resistenze corazzate. La temperatura di cottura è regolata termostaticamente. Dotato di termostato di sicurezza. Manopole di comando a labirinto che impediscono penetrazione di acqua all'interno durante le operazioni di pulizia.

**D** Elektro-Grillplatte, Tischmodell, 1/3 gerillt und 2/3 glatt verchromte Platte

Seitenwände, Boden und Rückseite aus Edelstahl. Arbeitsfläche hergestellt aus Edelstahl AISI 304 15/10. Kamin aus emailliertem Gusseisen. Grillplatte vollständig verschweißt und oben versiegelt. Grilloberfläche verchromt. 10 mm geneigte Oberfläche zum einfachen Sammeln von Fett. Ausziehbare Schublade zum Ablassen und Sammeln von Fett. Hochleistungsheizelemente. Kochtemperatur durch Thermostate überwacht. Mit Sicherheitsthermostat. Speziell designte Knöpfe, um das Eindringen von Wasser in das Bedienfeld zu vermeiden.

**E** Plancha eléctrica versión top, 1/3 rayada y 2/3 pulida cromada

Paneles laterales, fondo y respaldo fabricados en acero inoxidable. Tapa realizada en acero inoxidable AISI 304 15/10. Conduco de humos realizado en hierro fundido esmaltado. Placa calefactora empotrada totalmente soldada y sellada a la parte superior. Placa de cocción cromada. Superficie inclinada de 10 mm para recoger fácilmente la grasa. Cajón extraíble para drenaje y recogida de grasas. Elementos calefactores de alta resistencia. Temperatura de cocción controlada por termostatos. Con termostato de seguridad. Perillas de diseño especial para evitar la penetración de agua en el panel de control.

**FR** Fry-top électrique, top, 1/3 rainurée et 2/3 plaque lisse chromée

Panneaux latéraux, fond et dos en acier inoxydable. Plateau en acier inoxydable AISI 304 15/10. Conduit en fonte émaillée. Plaque de cuisson encastrée entièrement soudée et scellée vers le haut. Plaque de cuisson chromée. Surface inclinée de 10 mm pour recueillir facilement la graisse. Tiror extractible pour l'évacuation et la collecte des graisses. Éléments chauffants robustes. Température de cuisson surveillée par des thermostats. Avec thermostat de sécurité. Boutons spécialement conçus pour éviter la pénétration d'eau dans le panneau de commande.

Painéis laterais, fundo e verso em aço inoxidável. Tampo em aço inoxidável AISI 304 15/10. Conduta em ferro fundido esmaltado. Placa de aquecimento embutida totalmente soldada e vedada na parte superior. Placa de cozinha cromada. Superfície inclinada de 10 mm para fácil coleta de graxa. Gaveta extraível para drenagem e recolha de gorduras. Elementos de aquecimento resistentes. Temperatura de cozimento monitorada por termostatos. Com termostato de segurança. Botões especialmente projetados para evitar a penetração de água no painel de controle.

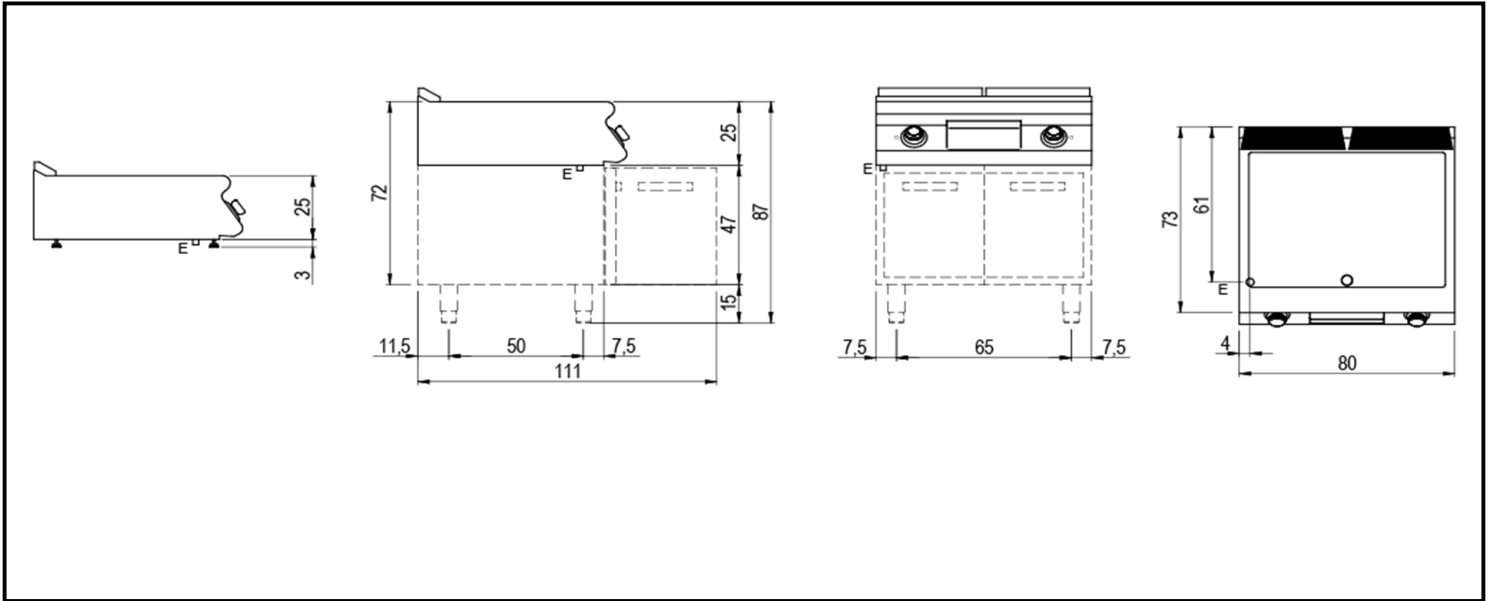

## OPTIONAL ACCESSORIES



**Code:** VRASFTR

Scraper for grooved griddle plates  
Schaber für gerillte Grillplatten

**Catalogue:** CATALOGUE

**Page:** V077



**Code:** VS7080B

Open cabinet 800 mm  
Offener Unterbau 800 mm

**Catalogue:** CATALOGUE

**Page:** V035



**Code:** VS80PRCAM

Flue extension line VS700 and VS900, w=800 mm  
Kaminverlängerung Serie VS700 und VS900, B=800 mm

**Catalogue:** CATALOGUE

**Page:** V076



**Code:** Z/GSFT

Scraper for smooth griddle plates  
Schaber für glatte Grillplatten

**Catalogue:** CATALOGUE

**Page:** 052CS



**Code:** Z/M95109400

Plug for fry-top simple version  
Stöpsel für Grillplatte Simple

**Catalogue:** CATALOGUE

**Page:** V063