

## Frozen Granita Dispenser with 2 bowls, electronic control and lighted panel

ITEM # \_\_\_\_\_

MODEL # \_\_\_\_\_

NAME # \_\_\_\_\_

SIS # \_\_\_\_\_

AIA # \_\_\_\_\_



560007 (IPRO2EL)

Frozen Granita Dispenser with 2X11 l insulated bowls, electronic control and lighted panel

### Short Form Specification

Item No. \_\_\_\_\_

Frozen granita dispenser with 2 bowls; the ITANK™ Technology prevents ice accumulation on the outer side of the bowl and the bowl shape allows a natural mixing action to ensure an optimum consistency of the product. Customizable lid merchandiser and back graphic. Electronic control system and touch screen keypad. Front illuminated panel. Sliding drip tray.

### Main Features

- Ideal for the production of slush.
- The ITANK™ Technology prevents ice accumulation on the outer side of the bowl, reducing condensation and increasing the cooling power of the machine.
- Bowl shape allows a natural mixing action to ensure an optimum consistency of the product.
- Customizable lid merchandiser and back graphic.
- The front illuminated panel provides customers with the opportunity to advertise their product and maximise impulse buying.
- Daily and weekly machine programming functionality.
- When the product reaches the right consistency, an automatic stand-by mode activates in order to save energy and reduce CO2 emissions.
- The insulated tank guarantees higher cooling efficiency and lower effect of the external temperature on product's preparation and maintenance time reducing condensing and draining; it is the best solution in hot climate conditions.

### Construction

- Electronic control system and touch screen keypad.
- Sliding drip tray.

APPROVAL: \_\_\_\_\_



**Electrolux**  
PROFESSIONAL

## Frozen Frozen granita dispenser with 2 bowls, electronic control and lighted panel

Front

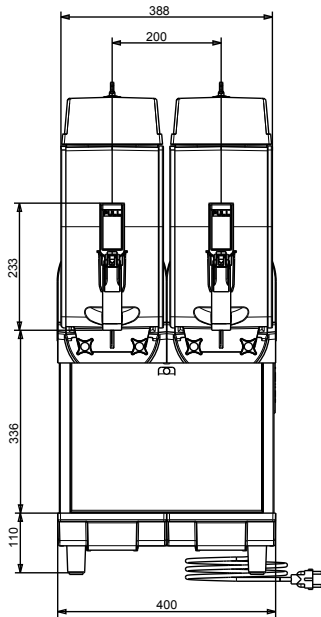

Side

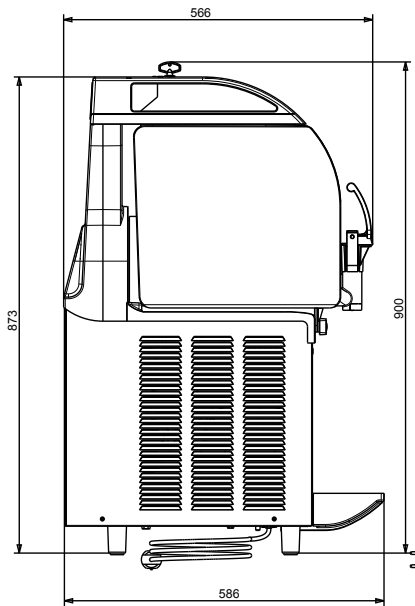

Top

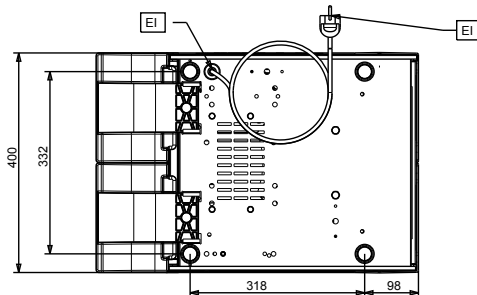

### Electric

Supply voltage:

560007 (IPRO2EL) 220-240 V/1 ph/50 Hz

Electrical power max.:

0.95 kW

### Key Information:

External dimensions, Width: 400 mm

External dimensions, Height: 870 mm

External dimensions, Depth: 580 mm

Net weight: 60 kg

### Refrigeration Data

Refrigerant type: R452A



Frozen  
Frozen granita dispenser with 2 bowls, electronic control and lighted panel  
The company reserves the right to make modifications to the products without prior notice. All information correct at time of printing.

2021.06.03