

SHP40

FAST SALAMANDERS HI-LITE PLUS

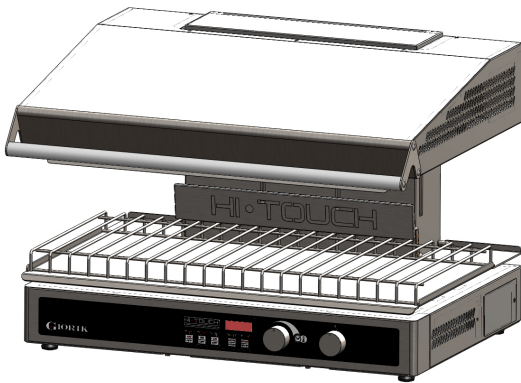

- Exclusive patented heating system.
- Cooktop in stainless steel grill.
- Wall support standard on all units.
- Dish detection function.
- HOLD function.

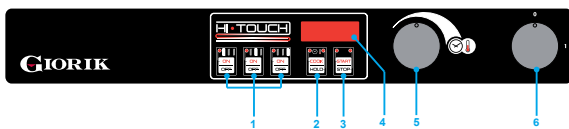

- 1 On/Off button for the heating elements.
- 2 Selection button for cooking mode (timed) or maintenance mode (unlimited duration).
- 3 Start/stop button for cooking/maintenance cycles.
- 4 Digital display.
- 5 Timer setting (max 20' in cook mode) and selection of maintenance among 8 levels in a temperature range from 40 to 70°C.
- 6 On/off knob.

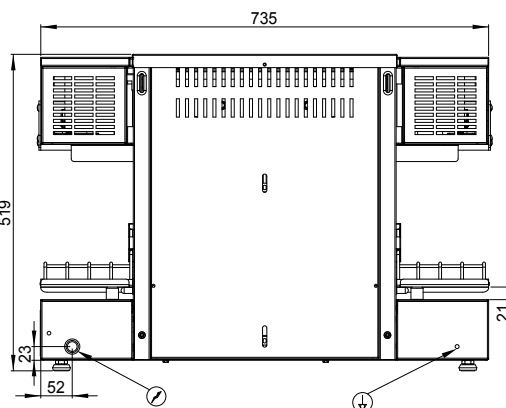
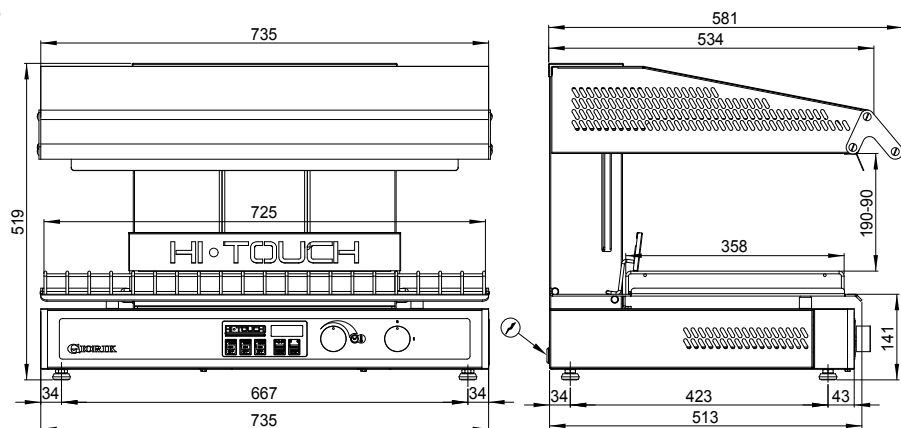

GENERAL TECHNICAL DATA

Package dimension (wxdxh)	cm 83x65x73
Package volume	m ³ 0,4
Weight	kg 80,5
Oven chamber power	-
Absorbed power	kW 5,3
Power supply voltage	3N 400V 50Hz
Chamber capacity	-
Distance between trays	-
Cooking chamber net dimensions(wxdxh)	-