

SCHEDA TECNICA

IT

Codice: PFE2713

Mod.: FP27S

Potenza	Kw	10
Alimentazione	3N 400V AC 50Hz	
Peso	Kg	31
Capacità	Lt.	35

- 1) TARGHETTA TECNICA
- 2) RUBINETTO SCARICO OLIO
- 3) VITE EQUIPOTENZIALE

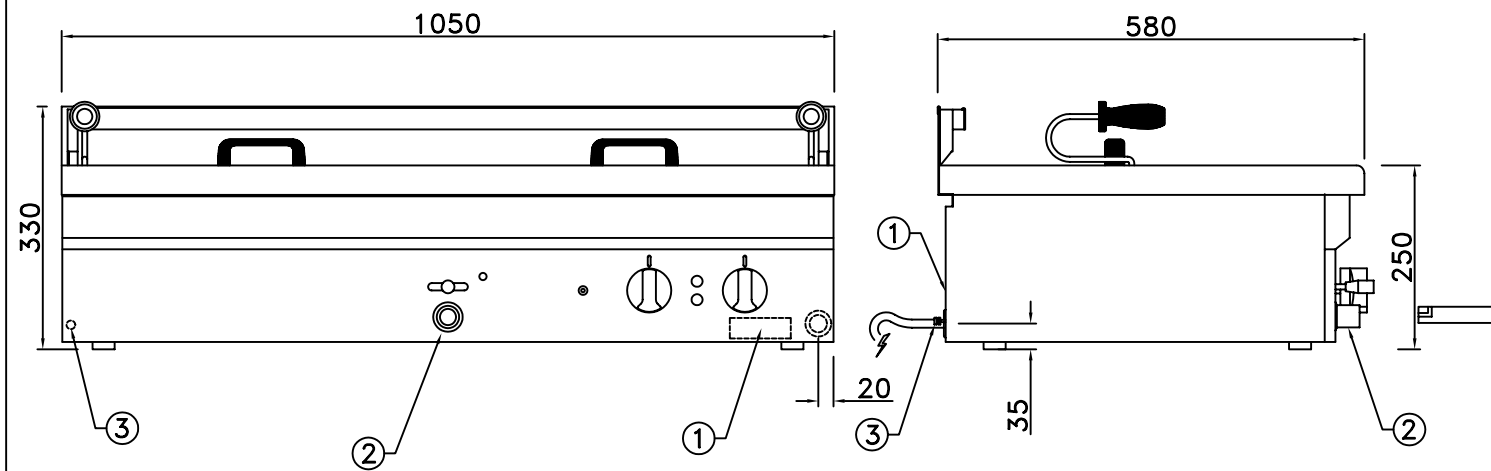

SCHEDA TECNICA

DE

Kode: PFE2713

Mod.: FP27S

Belastung	Kw	10
Spannung	3N 400V AC 50Hz	
Gewicht	Kg	31
Inhalt	Lt.	35

- 1) GERAETESCHILD
- 2) ABLASSHAHN
- 3) POTENTIALAUS GLEIHSCHRAUBE

GB

Code: PFE2713

Mod.: FP27S

Power	Kw	10
Feeding	3N 400V AC 50Hz	
Weight	Kg	31
Capacity	Lt.	35

- 1) RATING PLATE
- 2) DISCHARGE TAP
- 3) EQUIPOTENTIAL SCREW

FR

Code: PFE2713

Mod.: FP27S

Puissance	Kw	10
Alimentation	3N 400V AC 50Hz	
Poids	Kg	31
Capacité	Lt.	35

- 1) PLAQUE SIGNALÉTIQUE
- 2) ROBINET VIDANGE - HUILE
- 3) VIS EQUIPOTENTIELLE

ES

Código: PFE2713

Mod.: FP27S

Potencia	Kw	10
Alimentación	3N 400V AC 50Hz	
Peso	Kg	31
Capacidad	Lt.	35

- 1) PLACA TECNICA
- 2) GRIFO DE DESCARGO ACEITE
- 3) TARQUILLO EQUIPOTENCIAL