

## SCHEDA TECNICA

IT Codice: PFE1814

Mod.: FP18NS

|               |                 |    |
|---------------|-----------------|----|
| Potenza       | Kw              | 9  |
| Alimentazione | 3N 400V AC 50Hz |    |
| Peso          | Kg              | 24 |
| Capacità      | Lt.             | 21 |

- 1) TARGHETTA TECNICA
- 2) RUBINETTO SCARICO OLIO
- 3) VITE EQUIPOTENZIALE

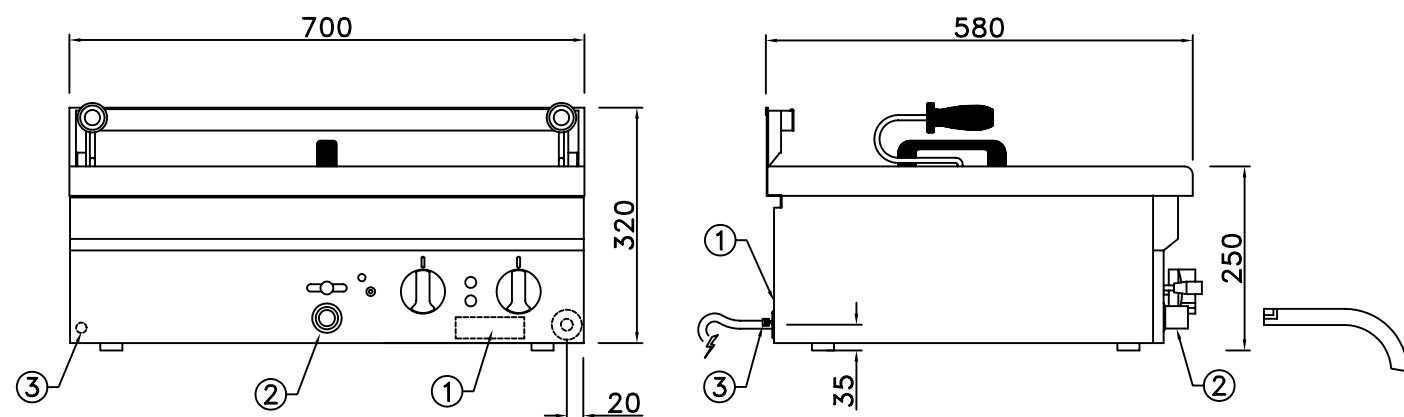

## SCHEDA TECNICA

DE Kode: PFE1814

Mod.: FP18NS

|           |                 |    |
|-----------|-----------------|----|
| Belastung | Kw              | 9  |
| Spannung  | 3N 400V AC 50Hz |    |
| Gewicht   | Kg              | 24 |
| Inhalt    | Lt.             | 21 |

- 1) GERAETESCHILD
- 2) ABLASSHAHN
- 3) POTENTIALAUS GLEIHSCHRAUBE

GB Code: PFE1814

Mod.: FP18NS

|          |                 |    |
|----------|-----------------|----|
| Power    | Kw              | 9  |
| Feeding  | 3N 400V AC 50Hz |    |
| Weight   | Kg              | 24 |
| Capacity | Lt.             | 21 |

- 1) RATING PLATE
- 2) DISCHARGE TAP
- 3) EQUIPOTENTIAL SCREW

FR Code: PFE1814

Mod.: FP18NS

|              |                 |    |
|--------------|-----------------|----|
| Puissance    | Kw              | 9  |
| Alimentation | 3N 400V AC 50Hz |    |
| Poids        | Kg              | 24 |
| Capacité     | Lt.             | 21 |

- 1) PLAQUE SIGNALÉTIQUE
- 2) ROBINET VIDANGE - HUILE
- 3) VIS EQUIPOTentielle

ES Còdigo: PFE1814

Mod.: FP18NS

|              |                 |    |
|--------------|-----------------|----|
| Potencia     | Kw              | 9  |
| Alimentación | 3N 400V AC 50Hz |    |
| Peso         | Kg              | 24 |
| Capacidad    | Lt.             | 21 |

- 1) PLACA TECNICA
- 2) GRIFO DE DESCARGO ACEITE
- 3) TARQUILLO EQUIPOTENCIAL