

# SCHEDA TECNICA

IT

Codice: PFE1813

Mod. : FP18S

Potenza	Kw	6.8
Alimentazione	3N 400V AC 50Hz	
Peso	Kg	24
Capacità	Lt.	21

- 1) TARGHETTA TECNICA
- 2) RUBINETTO SCARICO OLIO
- 3) VITE EQUIPOTENZIALE

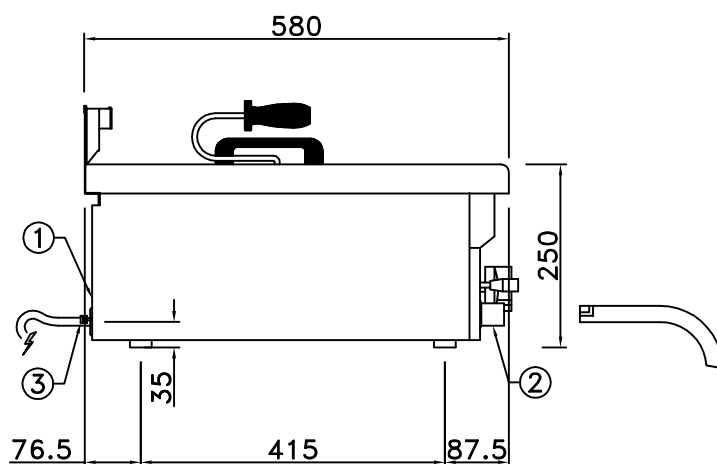
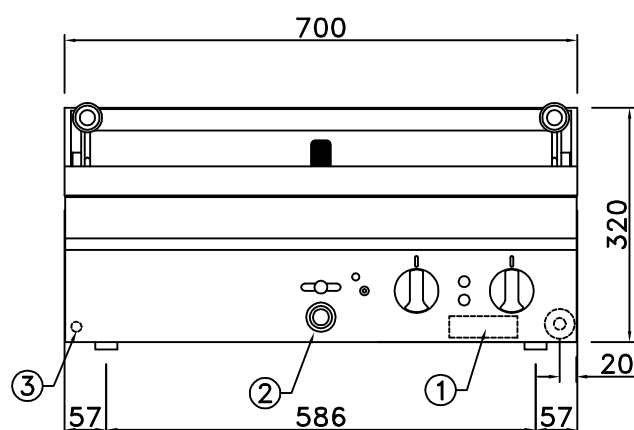

# SCHEDA TECNICA

DE

Kode: PFE1813

Mod. : FP18S

Belastung	Kw	6.8
Spannung	3N 400V AC 50Hz	
Gewicht	Kg	24
Inhalt	Lt.	21

- 1) GERAETESCHILD
- 2) ABLASSHAHN
- 3) POTENTIALAUS GLEIHSCHRAUBE

GB

Code: PFE1813

Mod. : FP18S

Power	Kw	6.8
Feeding	3N 400V AC 50Hz	
Weight	Kg	24
Capacity	Lt.	21

- 1) RATING PLATE
- 2) DISCHARGE TAP
- 3) EQUIPOTENTIAL SCREW

FR

Code: PFE1813

Mod. : FP18S

Puissance	Kw	6.8
Alimentation	3N 400V AC 50Hz	
Poids	Kg	24
Capacité	Lt.	21

- 1) PLAQUE SIGNALÉTIQUE
- 2) ROBINET VIDANGE – HUILE
- 3) VIS EQUIPOTentielle

ES

Código: PFE1813

Mod. : FP18S

Potencia	Kw	6.8
Alimentación	3N 400V AC 50Hz	
Peso	Kg	24
Capacidad	Lt.	21

- 1) PLACA TECNICA
- 2) GRIFO DE DESCARGO ACEITE
- 3) TARQUILLO EQUIPOTENCIAL