

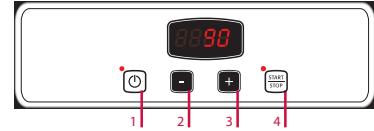

# GM2CE

## HOLDING OVEN 2 DRAWERS (1/1 GN) ELECTRONIC VERSION

- Aisi 430 oven chamber.
- Height-adjustable feet.
- Automatic preheating.
- Ergonomic handles to aid moving and bosses for stacking.
- Removable drawers



- 1 On/Off switch .
- 2 Increase temperature.
- 3 Decrease temperature.
- 4 Start/Stop cycle.

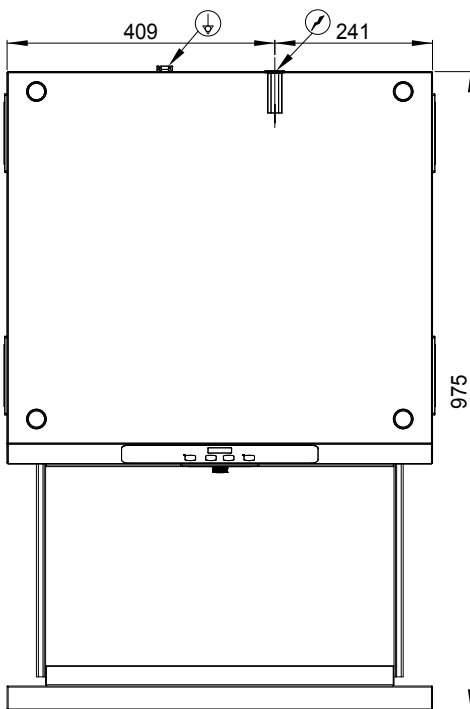
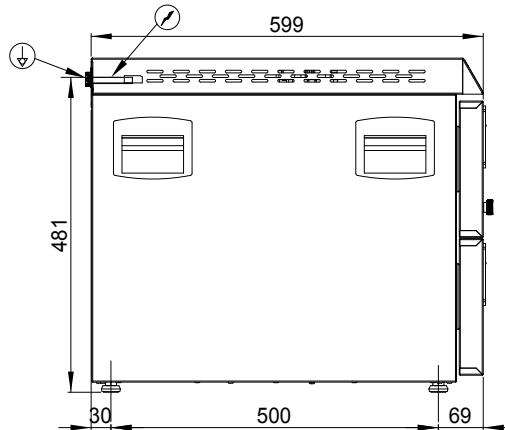
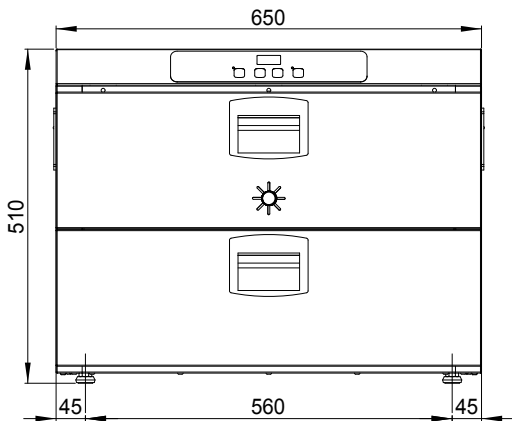

### TECHINICAL DATA

Dimensions: **650x599x510 mm**

Volume: **0,19 m<sup>3</sup>**

Weight: **35 Kg**

Chamber capacity: **2 drawers x(1/1 GN)**

Distance between drawers: **210 mm**

Oven cavity power: **0,9 kW**

Total electric power: **0,9 kW**

Power supply voltage: **1N 230V AC-50Hz**