

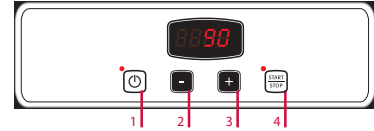

GM0511E

HOLDING OVEN 5 (1/1 GN) ELECTRONIC VERSION

- Aisi 430 oven chamber with rounded corners.
- Height-adjustable feet.
- Automatic preheating.
- Ergonomic handles to aid moving and bosses for stacking.
- Reversible door



- 1 On/Off switch.
- 2 Increase temperature.
- 3 Decrease temperature.
- 4 Start/Stop cycle.

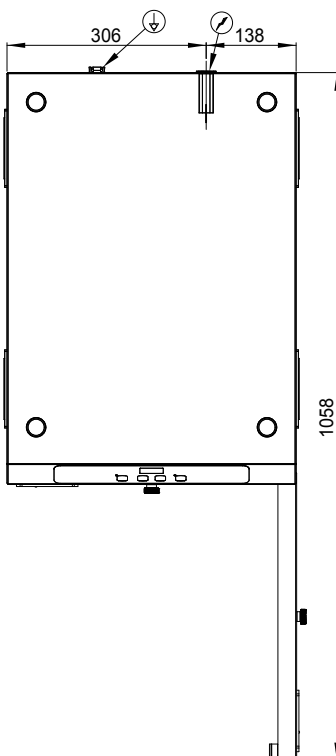
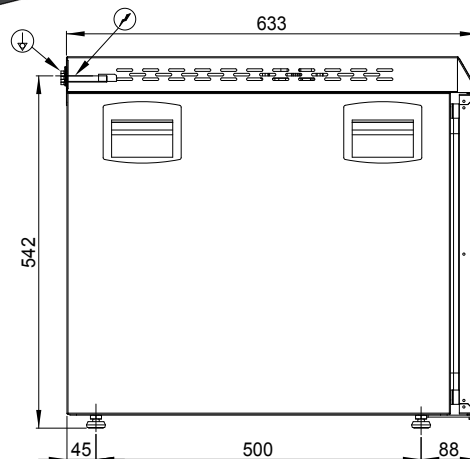
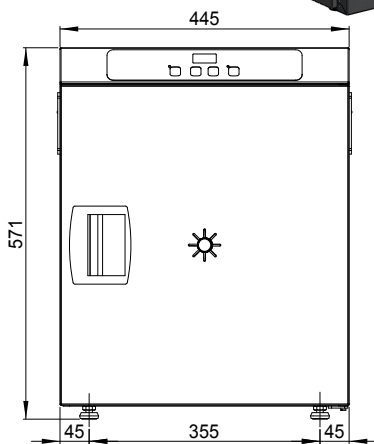
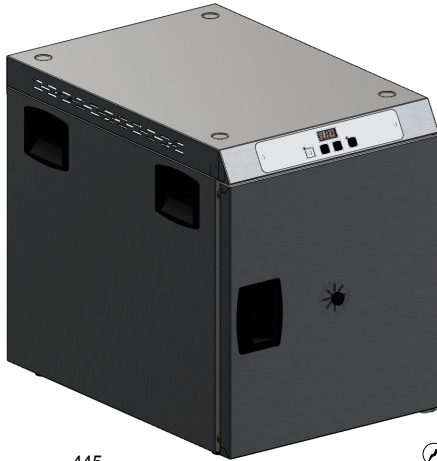

TECHINICAL DATA

Dimensions: **445x633x571 mm**

Volume: **0,16 m³**

Weight: **31 Kg**

Chamber capacity: **5x(1/1 GN)**

Distance between layers: **75 mm**

Net dimension of oven cavity: **370x420x550 mm (LxHxP)**

Oven cavity power: **1 kW**

Total electric power: **1 kW**

Power supply voltage: **1N 230V AC-50Hz**