

## SkyLine Pro LPG Gas Combi Oven 10GN2/1

ITEM # \_\_\_\_\_

MODEL # \_\_\_\_\_

NAME # \_\_\_\_\_

SIS # \_\_\_\_\_

AIA # \_\_\_\_\_



### Short Form Specification

#### Item No.

- Combi oven with digital interface with guided selection.
- Boilerless steaming function to add and retain moisture.
  - OptiFlow air distribution system to achieve maximum performance with 5 fan speed levels.
  - SkyClean: Automatic and built-in self cleaning system. 5 automatic cycles (soft, medium, strong, extra strong, rinse-only).
  - Cooking modes: Programs (a maximum of 100 recipes can be stored); Manual; EcoDelta cooking cycle.
  - Automatic backup mode to avoid downtime.
  - USB port to download HACCP data, programs and settings. Connectivity ready.
  - Single sensor core temperature probe.
  - Double-glass door with LED lights.
  - Stainless steel construction throughout.
  - Supplied with n.1 tray rack 2/1 GN, 67 mm pitch.

### Main Features

- Digital interface with LED backlight buttons with guided selection.
- Boilerless steaming function to add and retain moisture for high quality, consistent cooking results.
- Dry hot convection cycle (max 300 °C) ideal for low humidity cooking. Automatic moistener (11 settings) for boiler-less steam generation.
- EcoDelta cooking: cooking with food probe maintaining preset temperature difference between the core of the food and the cooking chamber.
- Programs mode: a maximum of 100 recipes can be stored in the oven's memory, to recreate the exact same recipe at any time. 4-step cooking programs also available.
- OptiFlow air distribution system to achieve maximum performance in cooking evenness and temperature control thanks to a special design of the cooking chamber combined with high precision variable speed fan and venting valve.
- Fan with 5 speed levels from 300 to 1500 RPM and reverse rotation for optimal evenness. Fan stops in less than 5 seconds when door is opened.
- Single sensor core temperature probe included.
- Automatic fast cool down and pre-heat function.
- SkyClean: Automatic and built-in self cleaning system. 5 automatic cycles (soft, medium, strong, extra strong, rinse-only).
- 3 different chemical options available: solid (phosphate-free), liquid (requires optional accessory), enzymatic.
- GreaseOut: predisposed for integrated grease drain and collection for safer operation (dedicated base as optional accessory).
- USB port to download HACCP data, share cooking programs and configurations. USB port also allows to plug-in sous-vide probe (optional accessory).
- Connectivity ready for real time access to connected appliances from remote and HACCP monitoring (requires optional accessory).
- Back-up mode with self-diagnosis is automatically activated if a failure occurs to avoid downtime.
- Capacity: 10 GN 2/1 or 20 GN 1/1 trays.
- Connectivity ready for real time access to connected appliances from remote and data monitoring (requires optional accessory - contact the Company for more details).

### Construction

- Human centered design with 4-star certification for ergonomics and usability.
- Wing-shaped handle with ergonomic design and hands-free opening with the elbow, making managing trays simpler (Registered Design at EPO).
- Double thermo-glazed door with open frame construction, for cool outside door panel. Swing hinged easy-release inner glass on door for easy cleaning.

APPROVAL: \_\_\_\_\_

- Seamless hygienic internal chamber with all rounded corners for easy cleaning.
- 304 AISI stainless steel construction throughout.
- Front access to control board for easy service.
- IPX 5 spray water protection certification for easy cleaning.
- Supplied with n.1 tray rack 2/1 GN, 67 mm pitch.

### Optional Accessories

- |  |            |   |
|--|------------|---|
| • Water softener with cartridge and flow meter (high steam usage)  | PNC 920003 | □ |
| • Water softener with salt for ovens with automatic regeneration of resin  | PNC 921305 | □ |
| • Resin sanitizer for water softener (921305)  | PNC 921306 | □ |
| • Wheel kit for 6 & 10 GN 1/1 and 2/1 GN oven base (not for the disassembled one)                                    | PNC 922003 | □ |
| • Pair of AISI 304 stainless steel grids, GN 1/1   | PNC 922017 | □ |
| • Pair of grids for whole chicken (8 per grid - 1,2kg each), GN 1/1  | PNC 922036 | □ |
| • AISI 304 stainless steel grid, GN 1/1  | PNC 922062 | □ |
| • AISI 304 stainless steel grid, GN 2/1  | PNC 922076 | □ |
| • External side spray unit (needs to be mounted outside and includes support to be mounted on the oven)              | PNC 922171 | □ |
| • Pair of AISI 304 stainless steel grids, GN 2/1   | PNC 922175 | □ |
| • Baking tray for 5 baguettes in perforated aluminum with silicon coating, 400x600x38mm                              | PNC 922189 | □ |
| • Baking tray with 4 edges in perforated aluminum, 400x600x20mm  | PNC 922190 | □ |
| • Baking tray with 4 edges in aluminum, 400x600x20mm   | PNC 922191 | □ |
| • Pair of frying baskets   | PNC 922239 | □ |
| • AISI 304 stainless steel bakery/pastry grid 400x600mm  | PNC 922264 | □ |
| • Double-step door opening kit   | PNC 922265 | □ |
| • Grid for whole chicken (8 per grid - 1,2kg each), GN 1/1   | PNC 922266 | □ |
| • Kit universal skewer rack and 6 short skewers for Lengthwise and Crosswise ovens                                   | PNC 922325 | □ |
| • Universal skewer rack  | PNC 922326 | □ |
| • 6 short skewers  | PNC 922328 | □ |
| • Water nanofilter for 10 GN 2/1 & 20 GN 1/1 & 2/1 ovens   | PNC 922344 | □ |
| • External reverse osmosis filter for ovens 10 GN 2/1 & 20 GN 1/1 & 2/1 ovens  | PNC 922345 | □ |
| • Multipurpose hook  | PNC 922348 | □ |
| • 4 flanged feet for 6 & 10 GN , 2", 100-130mm   | PNC 922351 | □ |
| • Grease collection tray, GN 2/1, H=60 mm  | PNC 922357 | □ |
| • Grid for whole duck (8 per grid - 1,8kg each), GN 1/1  | PNC 922362 | □ |
| • Thermal cover for 10 GN 2/1 oven and blast chiller freezer   | PNC 922366 | □ |
| • Tray support for 6 & 10 GN 2/1 disassembled open base  | PNC 922384 | □ |
| • Wall mounted detergent tank holder   | PNC 922386 | □ |
| • Tray rack with wheels 10 GN 2/1, 65mm pitch  | PNC 922603 | □ |
| • Tray rack with wheels, 8 GN 2/1, 80mm pitch  | PNC 922604 | □ |
| • Slide-in rack with handle for 6 & 10 GN 2/1 oven   | PNC 922605 | □ |
| • Bakery/pastry tray rack with wheels 400x600mm for 10 GN 2/1 oven and blast chiller freezer, 80mm pitch (8 runners) | PNC 922609 | □ |
| • Open base with tray support for 6 & 10 GN 2/1 oven   | PNC 922613 | □ |
| • Cupboard base with tray support for 6 & 10 GN 2/1 oven   | PNC 922616 | □ |
| • External connection kit for liquid detergent and rinse aid   | PNC 922618 | □ |
| • Stacking kit for gas 6 GN 2/1 oven placed on gas 6 GN 2/1 oven   | PNC 922625 | □ |
| • Trolley for slide-in rack for 10 GN 2/1 oven and blast chiller freezer   | PNC 922627 | □ |
| • Trolley for mobile rack for 6 GN 2/1 on 6 or 10 GN 2/1 ovens   | PNC 922631 | □ |
| • Stainless steel drain kit for 6 & 10 GN oven, dia=50mm   | PNC 922636 | □ |
| • Plastic drain kit for 6 & 10 GN oven, dia=50mm   | PNC 922637 | □ |
| • Trolley with 2 tanks for grease collection   | PNC 922638 | □ |
| • Grease collection kit for open base (trolley with 2 tanks, open/close device and drain)                            | PNC 922639 | □ |
| • Banquet rack with wheels holding 51 plates for 10 GN 2/1 oven and blast chiller freezer, 75mm pitch                | PNC 922650 | □ |
| • Dehydration tray, GN 1/1, H=20mm   | PNC 922651 | □ |
| • Flat dehydration tray, GN 1/1  | PNC 922652 | □ |
| • Open base for 6 & 10 GN 2/1 oven, disassembled - NO accessory can be fitted with the exception of 922384           | PNC 922654 | □ |
| • Heat shield for 10 GN 2/1 oven   | PNC 922664 | □ |
| • Heat shield-stacked for ovens 6 GN 2/1 on 10 GN 2/1  | PNC 922667 | □ |
| • Kit to convert from natural gas to LPG   | PNC 922670 | □ |
| • Kit to convert from LPG to natural gas   | PNC 922671 | □ |
| • Flue condenser for gas oven  | PNC 922678 | □ |
| • Kit to fix oven to the wall  | PNC 922687 | □ |
| • Tray support for 6 & 10 GN 2/1 oven base   | PNC 922692 | □ |
| • 4 adjustable feet with black cover for 6 & 10 GN ovens, 100-115mm  | PNC 922693 | □ |
| • Wifi board (NIU)   | PNC 922695 | □ |
| • Detergent tank holder for open base  | PNC 922699 | □ |
| • Mesh grilling grid, GN 1/1   | PNC 922713 | □ |
| • Probe holder for liquids   | PNC 922714 | □ |
| • Exhaust hood with fan for 6 & 10 GN 2/1 GN ovens   | PNC 922729 | □ |
| • Exhaust hood with fan for stacking 6+6 or 6+10 GN 2/1 ovens  | PNC 922731 | □ |
| • Exhaust hood without fan for 6&10x2/1 GN oven  | PNC 922734 | □ |

- Exhaust hood without fan for stacking 6+6 or 6+10 GN 2/1 ovens  PNC 922736
- 4 high adjustable feet for 6 & 10 GN ovens, 230-290mm  PNC 922745
- Tray for traditional static cooking, H=100mm  PNC 922746
- Double-face griddle, one side ribbed and one side smooth, 400x600mm  PNC 922747
- Trolley for grease collection kit  PNC 922752
- Water inlet pressure reducer  PNC 922773
- Kit for installation of electric power peak management system for 6 GN and 10 GN ovens  PNC 922774
- Non-stick universal pan, GN 1/1, H=20mm  PNC 925000
- Non-stick universal pan, GN 1/1, H=40mm  PNC 925001
- Non-stick universal pan, GN 1/1, H=60mm  PNC 925002
- Double-face griddle, one side ribbed and one side smooth, GN 1/1  PNC 925003
- Aluminum grill, GN 1/1  PNC 925004
- Frying pan for 8 eggs, pancakes, hamburgers, GN 1/1  PNC 925005
- Flat baking tray with 2 edges, GN 1/1  PNC 925006
- Potato baker for 28 potatoes, GN 1/1  PNC 925008
- Compatibility kit for installation on previous base GN 2/1  PNC 930218

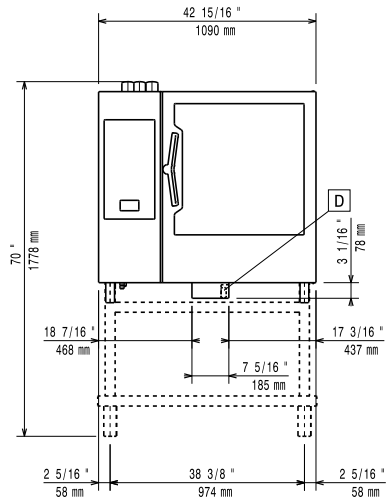
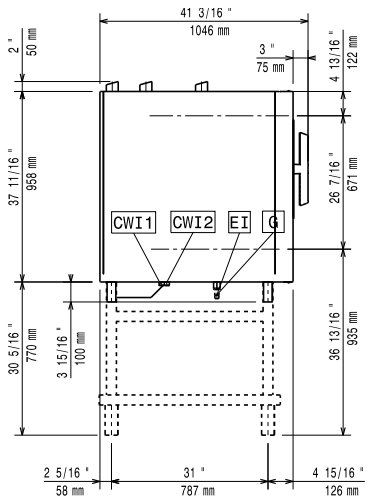
**Front**

**Side**

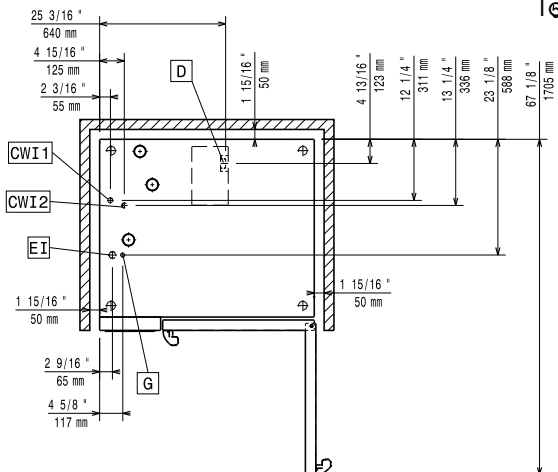
- CWI1 = Cold Water inlet 1 (cleaning)
- CWI2 = Cold Water Inlet 2 (steam generator)
- D = Drain
- DO = Overflow drain pipe
- EI = Electrical inlet (power)
- G = Gas connection

**Top**

### Electric

<b>Supply voltage:</b>	217963 (ECO102C2H0)	220-240 V/1 ph/50 Hz
<b>Electrical power, default:</b>		1.5 kW
<b>Electrical power max.:</b>		1.5 kW
<b>Circuit breaker required</b>		

### Gas

<b>Gas Power:</b>	35 kW
<b>Standard gas delivery:</b>	LPG. G31
<b>ISO 7/1 gas connection diameter:</b>	1/2" MNPT
<b>LPG:</b>	
<b>Total thermal load:</b>	140916 BTU (35 kW)

### Water:

<b>Water inlet connections "CWI1-CWI2":</b>	3/4"
<b>Pressure, bar min/max:</b>	1-4.5 bar
<b>Drain "D":</b>	50mm
<b>Max inlet water supply temperature:</b>	30 °C
<b>Hardness:</b>	5 °fH / 2.8 °dH
<b>Chlorides:</b>	<10 ppm
<b>Conductivity:</b>	>285 µS/cm

**Electrolux** recommends the use of treated water, based on testing of specific water conditions.  
 Please refer to user manual for detailed water quality information.

### Installation:

<b>Clearance:</b>	Clearance: 5 cm rear and right hand sides.
<b>Suggested clearance for service access:</b>	50 cm left hand side.

### Capacity:

<b>Trays type:</b>	10 - 2/1 Gastronorm
<b>Max load capacity:</b>	100 kg

### Key Information:

<b>Door hinges:</b>	Right Side
<b>External dimensions, Width:</b>	1090 mm
<b>External dimensions, Height:</b>	1058 mm
<b>External dimensions, Depth:</b>	971 mm
<b>Weight:</b>	182 kg
<b>Net weight:</b>	182 kg
<b>Shipping weight:</b>	209 kg
<b>Shipping volume:</b>	1.58 m <sup>3</sup>